

Tool Clamping

Delivery Programme

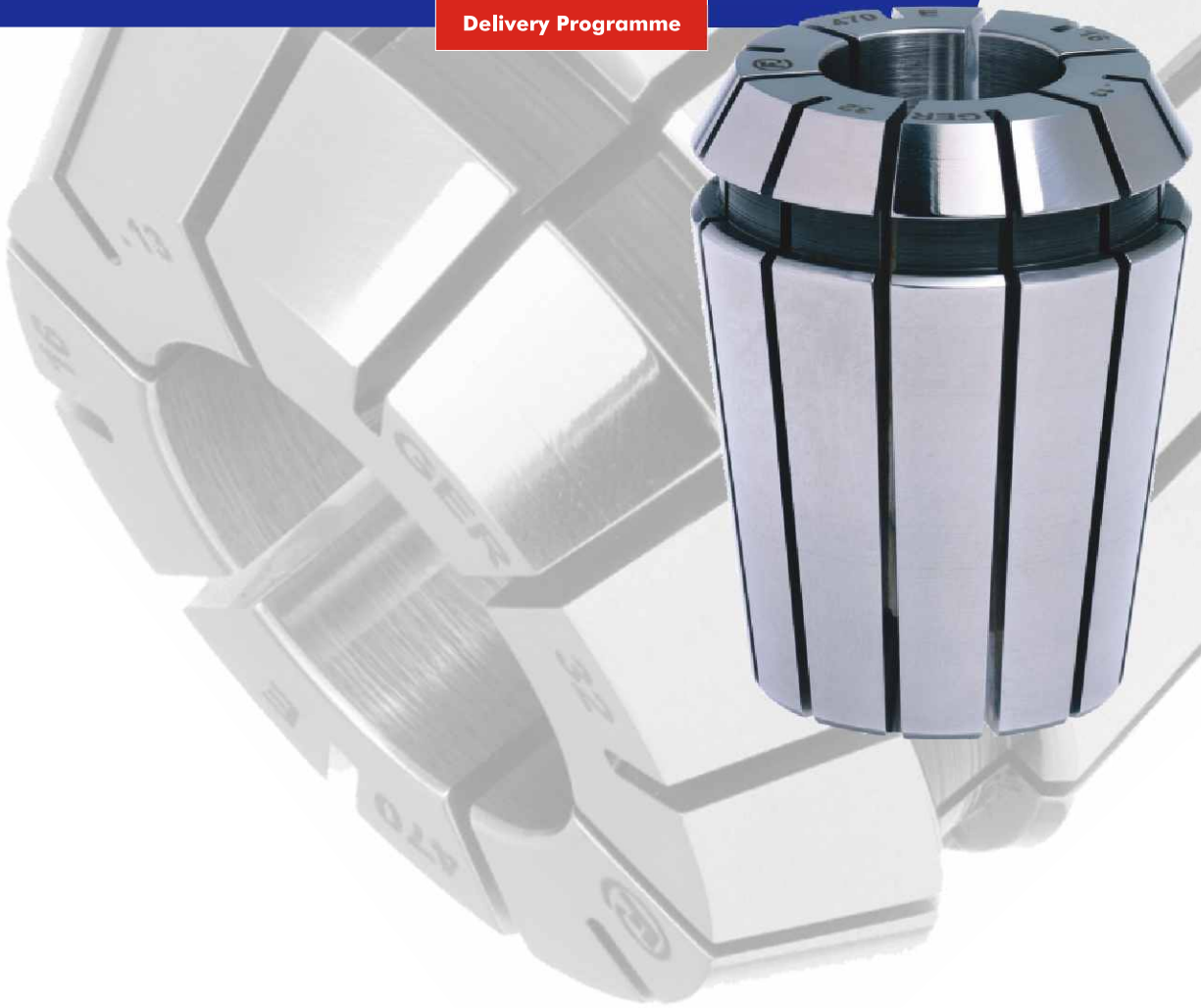

FAHRION®
PRÄZISION

Collets for Tool Clamping

Page 4	Collets GER BER ET DIN6499/ISO15488 (ER/ESX)	
Page 12	Taper Wipers KW-ER for Collet Closing Tapers DIN6499/ISO15488 (ER/ESX)	
Page 13	Clamping Nuts STM GMER DIN6499/ISO15488 (ER/ESX)	
Page 16	Wrenches SCHL for Clamping Nuts DIN6499/ISO15488 (ER/ESX)	
Page 17	Collets HF RT DIN6388/ISO10897 (OZ)	
Page 20	Clamping Nuts KM DIN6388/ISO10897 (OZ)	
Page 20	Wrenches SCHL for Clamping Nuts DIN6388/ISO10897 (OZ)	
Page 21	Erickson Double Angle Collets DK/DA	
Page 21	Erickson Clamping Nuts STMDA DK/DA	
Page 22	Erickson Collets DF/TG	
Page 22	Erickson Clamping Nuts STMTG DF/TG	
Page 22	Collets HX with Hexagon Head	
Page 23	Split Sleeves SL-BO DIN6329 with Morse Taper	
Page 23	Split Sleeves SL-GB DIN6328 with Morse Taper	
Page 23	Clamping Sleeves SH with Morse Taper	
Page 24	Rubber-Flex® Collets RFJ	
Page 24	Rubber-Flex® Clamping Nuts STM	
Page 24	Wrenches SCHL for Rubber-Flex® Clamping Nuts	





Collet Holders for Tool Clamping

Page 25	Collet Holders NCER with Cylindrical Shank and Flat	
Page 25	VDI Collet Holders HFERD with shank DIN69880	
Page 26	Collet Holders HFER with Morse Taper Shank	
Page 26	Collet Holders HF with Morse Taper Shank	

Collet Holders for Tool Clamping

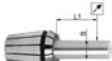
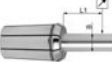
	Collet Holders HFER with Cylindrical Shank	Page 27
	Collet Holders HFERM with Cylindrical Shank	Page 28
	Collet Holders HFERM with Cylindrical Shank and Flat	Page 29
	Collet Holders HFERM with Cylindrical Shank, Flat and Coolant Connection	Page 29
	Collet Holders HFERM with Cylindrical Shank and Flat	Page 30
	Double Collet Holders DHER with Cylindrical Shank and Flat	Page 31
	Collet Holders HFERM with B-Taper and Flat	Page 32
	Collet Holders HF with Cylindrical Shank and Flat	Page 32
	Drill Holders BHRFJ with Cylindrical Shank and Flat	Page 32
	VDI Tapping Holders GBH with Shank DIN69880	Page 33
	VDI Floating Reamer Holders PHER with Shank DIN69880	Page 33
	Tapping Holders GBH with Cylindrical Shank	Page 34
	Double Tapping Holders DGBH with Cylindrical Shank and Flat	Page 35
	Drill-Tapping Holders HFER/GBH with Cylindrical Shank and Flat	Page 35
	Floating Reamer Holders PHER with Cylindrical Shank	Page 36
	Floating Reamer Holders PHER/PHERM with Cylindrical Shank	Page 37

Appendix

	Concentricity Charts for Collets DIN6499/ISO15488 (ER/ESX)	Page 38
	Concentricity Charts for Collets DIN6388/ISO10897 (OZ)	Page 39
	Build-in Dimensions for Collets DIN6499/ISO15488 (ER/ESX)	Page 39
	Tightening Torque for Clamping Nuts DIN6499/ISO15488 (ER/ESX)	Page 40
	Mounting Instructions for Collets and Clamping Nuts DIN6499/ISO15488 (ER/ESX) and DIN6388/ISO10897(OZ)	Page 41
	Tap Shank Dimensions DIN/ISO	Page 42

We reserve the right to change the design and specification of any product shown within this catalogue, which does not result in the adverse function of the corresponding tools.

Advantages of FAHRION Collets DIN6499/ISO15488-forms B and HP (ER/ESX)



In addition to slots being deburred, finish of operating surfaces $\leq 1,6 \mu\text{m}$

FAHRION provides the largest range of forms and executions of collets DIN 6499/ISO15488 (ER/ESX) for different applications









Precise - FAHRION collets **DIN6499/ISO15488-form B (ER/ESX)** set new standards of **concentricity and repeatability**, which is $6 \mu\text{m}$ for the types **GER11 up to GER40**

Rigid - **12 slots** are sufficient in order to reach the required collapse to **DIN6499/ISO15488**. This is possible because of a special steel produced for us and a particular harmonized heat treatment. Compared to 16 slot collets, our collets have less tendency to distort

Saving - all edges are not only deburred, but additionally rounded, which is a prerequisite to protect the inner cone of the collet chuck from marks. This process is important to guarantee a consistent repeatable high accuracy

Increased rigidity and clamping forces, improved grip, higher precision and system concentricity, enhanced resistance to corrosion for GER-B, GER-HP, GER-HP+, GER-D, GER-DD due to super-finished execution (see picture on the left!)

Features of FAHRION Collets DIN6499/ISO15488 (ER/ESX)

Form/Application	GER-B ¹	GER-HP	GER-HP+	BER-K2	GER-D	GER-DD	GER-GB	ET
								
DIN6499/ISO15488 - form	B	B	B	B	A2	A2	A2	A2
Slots	12 times	12 times	12 times	16 times	8 times	8 times	8 times	none
Standard Collet Chuck	X	X	-	X	X	X	X	X
FAHRION Precision Collet Chuck HPplus	X ³	X	X	-	-	-	-	-
Concentricity e.g. \varnothing 12,0 mm	6 μm	3 μm	3 μm	20 μm	6 μm	6 μm	10 μm	20 μm
Repeatability	6 μm	3 μm	3 μm	10 μm	6 μm	6 μm	6 μm	10 μm
Concentricity important	X	X	-	-	X	X	-	-
Concentricity very important for HSC	-	X	X	-	-	-	-	-
Concentricity/tool life unimportant	-	-	-	X	-	-	-	-
Collapse	0,5-2 mm	0,5-1 mm ⁴	h10	0,5-1 mm	h8	h8	-	-
Sealing for IC (inner coolant supply)	-	-	X	-	X	-	-	-
Sealing for IC and jet holes	-	-	-	-	-	X	-	-
For tapping with internal square drive	-	-	-	-	-	-	X	-
With incorporated axial compensation	-	-	-	-	-	-	-	X
Details to be found on page	6	7	8	9	10	10	11	12

1 unless otherwise indicated, form GER-B will be supplied!
 2 collets DIN6499/ISO15488-form A are completely interchangeable with collets form B, but do not fit into our Precision Collet Chucks HPplus
 3 can be used, but the concentricity of the complete system is influenced
 4 highest concentricity of the complete system when clamping nominal size \varnothing h10

Only original FAHRION collets forms GER-B, GER-HP, GER-HP+, GER-D, GER-DD and GER-GB are indicated by this trademark



FAHRION trademark for tested quality

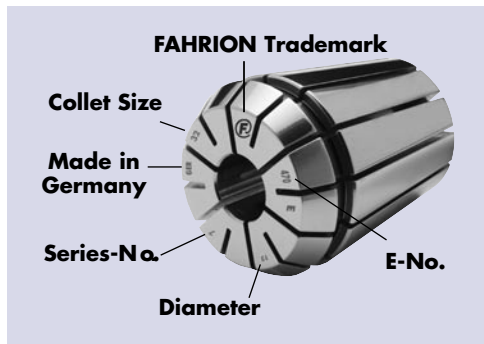

What are the advantages for you?

Higher tool working life, lower tool costs, less setting up time

→ **Lower production costs**

Better surface finishes and tighter production tolerances

→ **Improved quality**

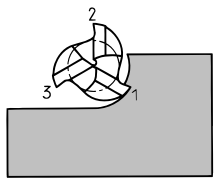

Irregular load on the cutting edges

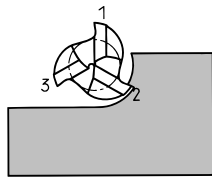

Wear on tool increases, surface quality of the workpiece is getting worse

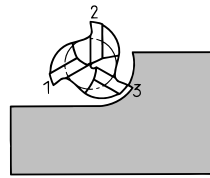

Feed has to be reduced

Effect of runout on the cutting edges

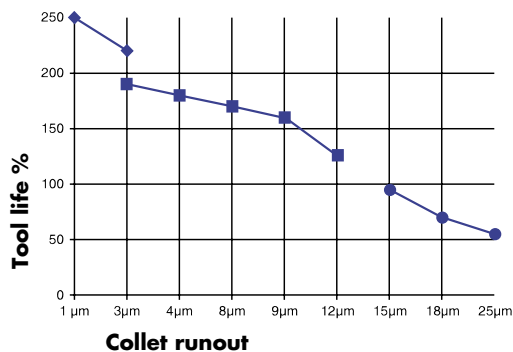

Influence of collet accuracy on the life of carbide cutting tools

- ◆ FAHRION HP+, HP
- FAHRION B, D, DD
- DIN class 2 (K2)

Cost example for a carbide drill Ø 12 mm with collet DIN6499/ISO15488-form B, type 470 E

Example 1: system concentricity ≤ 10 µm

Cost of a carbide drill	approx. 80,00 €
Cost FAHRION GER32-B collet with concentricity 6µm	approx. 17,00 €
Cost on basis of tool life of approx. 150 %	approx. 97,00 €

Example 2: system concentricity ≤ 25 µm

Cost of a carbide drill	approx. 80,00 €
Cost BER32-K2 collet DIN class 2 with concentricity 20µm	approx. 8,00 €
Cost on basis of tool life of approx. 55 %	approx. 88,00 €
Cost for similar tool life of approx. 150 %	approx. 238,00 €
More than two carbide drills necessary!	

Result: Cheap collets almost triple the costs!

Type GER-B

Precision Collets
DIN6499/ISO15488-B
(ER/ESX) – form B

6µm at B!

Form GER8:

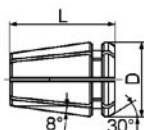

Form GER11 to GER50:

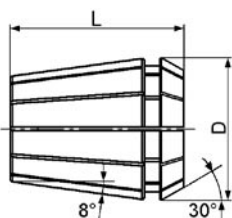

= concentricity
T = collapse



Concentricity and repeatability – concentricity see in chart/repeatability 6µm, i.e. system accuracy ≤ 8µm with Centro P collet chucks and 6µm collets

Application – for HSC and for high precision work

Collapse – nominal size reduced by T

E-No. Description	Order-No.		T	D	L	P	from-to	steps
4004E GER8-B *	13010	10µm	-0,5	8,5	12	●	1,0-5,0	0,5
4008E GER11-B	13000	6µm	-0,5	11,5	18	●	1/16"•1/8"•3/16"	0,5
424E GER12-B *	13012	6µm	-0,5 -1,0	12	19,5	●	1,0-3,0	0,5
426E GER16-B	13001	6µm	-0,5 -1,0	17	27,5	●	1,0-1,5 2,0-10,0	0,5
428E GER20-B	13002	6µm	-0,5 -1,0	21	31,5	●	1/16"•1/8"•5/32"•3/16"•7/32"•1/4"•9/32"•5/16"•11/32"•3/8"•13/32"	0,5
430E GER25-B	13003	6µm	-0,5 -1,0	26	34	●	1,0-1,5 2,0-13,0	0,5
470E GER32-B	13004	6µm	-0,5 -1,0	33	40	●	1/8"•3/16"•1/4"•5/16"•3/8"•7/16"•1/2"•9/16"•5/8"•11/16"•3/4"•13/16"	0,5
472E GER40-B	13005	6µm	-1,0	41	46	●	3,0-26,0 27,0-30,0	0,5 1,0
477E GER50-B *	13006	10µm	-2,0	51,8	60,3	●	1/4"•5/16"•3/8"•7/16"•1/2"•9/16"•5/8"•3/4"•7/8"•1"	2,0
						●	6,0-34,0 25,0	2,0

Sets in Wooden Boxes – form B



Also available – sets of collets DIN6499/ISO15488-B (ER/ESX) – form B in wooden boxes

E-No. Description	Order-No.	Set		P	Content of set from-to	steps
4004E GER8-B	1301016	9 pieces	10µm	●	1,0-5,0	0,5
4008E GER11-B	1300016	13 pieces	6µm	●	1,0-7,0	0,5
426E GER16-B	1300116	10 pieces	6µm	●	1,0-10,0	1,0
428E GER20-B	1300216	12 pieces	6µm	●	2,0-13,0	1,0
430E GER25-B	1300316	15 pieces	6µm	●	2,0-16,0	1,0
470E GER32-B	1300416	18 pieces	6µm	●	3,0-20,0	1,0
472E GER40-B	1300516	23 pieces	6µm	●	4,0-26,0	1,0

Concentricity and repeatability – average of $3\mu\text{m}$ checked with HPplus and $\leq 5\mu\text{m}$ with Centro P collet chucks • checked in four equi-spaced positions (moved clockwise by 90°) at a distance of $3x D$ (max. 50 mm)

Application – for HSC and for high precision work with FAHRION HPplus and Centro P collet chucks (see separate catalogues)

Collapse – nominal size reduced by T, with HPplus and Centro P h10 • in order to assure the best concentricity and repeatability we recommend to clamp only the nominal size h10 with HP collets • intermediate diameters should be ground to nominal size, if possible

E-No. Description	Order-No.		T	D	L	P	from-to	steps
® 4008E GER11-HP	13020	$3\mu\text{m}$	-0,5	11,5	18	●	1,0-7,0	0,5
							1/16"•1/8"•3/16"•1/4"	
® 426E GER16-HP	13021	$3\mu\text{m}$	-0,5	17	27,5	●	1,0-1,5	0,5
			-1,0				2,0-10,0	0,5
							1/8"•3/16"•1/4"•5/16"•3/8"	
® 428E GER20-HP	13022	$3\mu\text{m}$	-1,0	21	31,5	●	2,0-13,0	0,5
							1/8"•3/16"•1/4"•5/16"•3/8"•7/16"•1/2"	
® 430E GER25-HP	13023	$3\mu\text{m}$	-1,0	26	34	●	2,0-16,0	0,5
							1/8"•3/16"•1/4"•5/16"•3/8"•7/16"•1/2"•9/16"•5/8"	
® 470E GER32-HP	13024	$3\mu\text{m}$	-1,0	33	40	●	2,0-20,0	0,5
							1/8"•3/16"•1/4"•5/16"•3/8"•7/16"•1/2"•9/16"•5/8"•3/4"	
® 472E GER40-HP	13025	$3\mu\text{m}$	-1,0	41	46	●	3,0-26,0	0,5
							1/4"•3/8"•1/2"•5/8"•3/4"•7/8"•1"	

Also available – sets of collets DIN6499/ISO15488-B (ER/ESX) – form HP in wooden boxes

E-No. Description	Order-No.	Set		P	Content of set from-to	steps
® 4008E GER11-HP	1302016	13 pieces	$3\mu\text{m}$	●	1,0-7,0	0,5
® 426E GER16-HP	1302116	10 pieces	$3\mu\text{m}$	●	1,0-10,0	1,0
® 428E GER20-HP	1302216	12 pieces	$3\mu\text{m}$	●	2,0-13,0	1,0
® 430E GER25-HP	1302316	15 pieces	$3\mu\text{m}$	●	2,0-16,0	1,0
® 470E GER32-HP	1302416	18 pieces	$3\mu\text{m}$	●	3,0-20,0	1,0
® 472E GER40-HP	1302516	23 pieces	$3\mu\text{m}$	●	4,0-26,0	1,0

Type GER-HP

Precision Collets
DIN6499/ISO15488-B
(ER/ESX) – form HP

3 μm at HP!

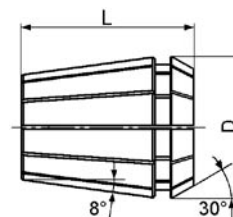

 = concentricity
T = collapse



Sets in Wooden Boxes – form HP



Type GER-HP+

**Precision Collets
DIN6499/ISO15488-B
(ER/ESX) – form HP+
with Seals**

3µm at HP+!

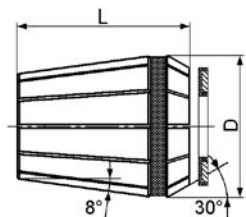

☑ = concentricity

T = collapse



Concentricity and repeatability – average of 3µm checked with HPplus and ≤ 5µm with Centro P collet chucks • checked in four equi-spaced positions (moved clockwise by 90°) at a distance of 3xD (max. 50 mm)

Application – for HSC and for high precision work with FAHRION HPplus and Centro P collet chucks (see separate catalogues)

Collapse – h10 • please note the reduced collapse of HPplus and Centro P collet chucks!

Special features – coloured ring only for identification (not sealing ring) • collets are always delivered with suitable seals (can be used up to 80 bar – collapse +0,4/-0,1) • spare seals see page 15

E-No. Description	Order-No.	☑	T	D	L	P	from-to	steps
® 426E GER16-HP+	13041	3µm	h10	17	27,5	●	1,0-1,5	0,5
						●	1,1-1,4 + 1,6-1,9	0,1
						●	2,0-10,0	0,5
						●	2,1-2,4 + 2,6-2,9	0,1
						●	3,1-3,4 + 3,6-3,8	0,1
						●	5,6•6,3•7,1	
® 430E GER25-HP+	13043	3µm	h10	26	34	●	2,0-16,0	0,5
						●	1/8"•3/16"•1/4"•5/16"•3/8"•7/16"•1/2"•9/16"•5/8"	
® 470E GER32-HP+	13044	3µm	h10	33	40	●	2,0-20,0	0,5
						●	1/8"•3/16"•1/4"•5/16"•3/8"•7/16"•1/2"•9/16"•5/8"•3/4"	
® 472E GER40-HP+	13045	3µm	h10	41	46	●	3,0-26,0	0,5
						●	1/4"•3/8"•1/2"•5/8"•3/4"•7/8"•1"	

**Precision Collets
DIN6499/ISO15488-B
(ER/ESX) – form GER-HP+
with Seals inserted in
HPplus Chucks**



HP32 with carbide reamer

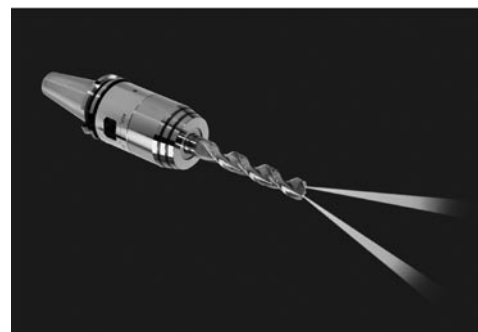

HP40 with drill

Concentricity and repeatability – concentricity to DIN/ISO class 2 see  in chart/repeatability 10µm

Application – use only, if concentricity and life time of cutting tool are unimportant

Collapse – nominal size reduced by T

E-No. Description	Order-No.		T	D	L	P	from-to	steps	
4004E BER8-K2 *	13210	15µm	-0,5	8,5	13,5	●	1,0-5,0	0,5	
4008E BER11-K2	13200	15µm	-0,5	11,5	18	●	1,0-7,0	0,5	
426E BER16-K2	13201	15µm	-0,5	17	27,5	●	1,0	1,0	
			-1,0		21,7	●	11,0-12,0 *		
428E BER20-K2	13202	15µm	-0,5	21	31,5	●	2,0-10,0	1,0	
			-1,0		31	●	11,0-13,0		
					20µm	27,5	●		14,0 *
430E BER25-K2	13203	15µm	-1,0	26	34	●	2,0-2,5	0,5	
						●	3,0-10,0	1,0	
						20µm	●	11,0-16,0	1,0
							●	17,0 *	
							●	18,0 *	
470E BER32-K2	13204	15µm	-1,0	33	40	●	19,0 *		
						●	20,0 *		
						20µm	●	2,0-2,5	0,5
							●	3,0-10,0	1,0
472E BER40-K2	13205	15µm	-1,0	41	46	●	11,0-20,0	1,0	
						●	21,0 *		
						20µm	●	3,0-10,0	1,0
						●	11,0-26,0	1,0	

* BER8-K2 and short executions are not included in the DIN/ISO-standard

Also available – sets of collets to DIN6499/ISO15488-B (ER/ESX) – form K2 on wooden trays

E-No. Description	Order-No.	Set		P	Content of set from-to	steps
4008E BER11-K2	1320018	13 pieces	15µm	●	1,0-7,0	0,5
426E BER16-K2	1320118	10 pieces	15µm	●	1,0-10,0	1,0
428E BER20-K2	1320218	12 pieces	15-20µm	●	2,0-13,0	1,0
430E BER25-K2	1320318	15 pieces	15-20µm	●	2,0-16,0	1,0
470E BER32-K2	1320418	18 pieces	15-20µm	●	3,0-20,0	1,0
472E BER40-K2	1320518	23 pieces	15-20µm	●	4,0-26,0	1,0

Type BER-K2

Collets DIN6499/ ISO15488-B (ER/ESX) – form K2

Form BER8

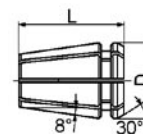

Form BER11 to BER40

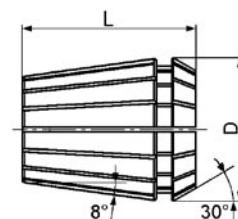

 = concentricity
T = collapse



Sets on Wooden Trays – form K2



Type GER-D

Coolant Collets
DIN6499/ISO15488-A
with Seal for IC – form D

6µm at D!

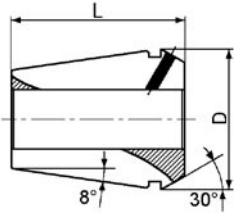

☑ = concentricity
T = collapse



Concentricity and repeatability – concentricity see ☑ in chart/repeatability 6µm, i.e. system accuracy ≤ 10µm with standard precision collet chucks

Application – for HSC and for high precision work with inner coolant supply, but not with HPplus and Centro P collet chucks

Collapse – h8, i.e. only nominal size can be clamped

Special features – with seals for inner coolant supply (can be used up to 120 bar)

Remark – shanks with lateral flat can be used only qualified, i.e. the flat must be behind the rubber seals in order to reach a complete sealing

E-No. Description	Order-No.	☑	T	D	L	P	from-to	steps
☑ 4012E GER11-D	13400	6µm	h8	11,3	18	●	3,0-7,0	1,0
						●	1/8"•3/16"•1/4"	
☑ 425E GER16-D	13401	6µm	h8	16,7	27,5	●	3,0-10,0	1,0
						●	1/8"•3/16"•1/4"•5/16"•3/8"	
						●	3,0-13,0	
☑ 427E GER20-D	13402	6µm	h8	20,7	31,5	●	1/8"•3/16"•1/4"•5/16"•3/8"•7/16"•1/2"	1,0
☑ 429E GER25-D	13403	6µm	h8	25,7	34	●	3,0-16,0	1,0
						●	1/8"•3/16"•1/4"•5/16"•3/8"•7/16"•1/2"•9/16"•5/8"	
☑ 469E GER32-D	13404	6µm	h8	32,7	40	●	3,0-20,0	1,0
						●	1/8"•3/16"•1/4"•5/16"•3/8"•7/16"•1/2"•9/16"•5/8"•3/4"	
☑ 471E GER40-D	13405	6µm	h8	40,7	46	●	4,0-26,0	1,0
						●	1/4"•5/16"•3/8"•7/16"•1/2"•9/16"•5/8"•3/4"•7/8"•1"	

Type GER-DD

Coolant Collets
DIN6499/ISO15488-A
with Seal for IC and Jet
Hole – form DD

6µm at DD!

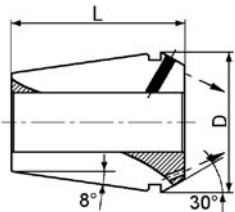

☑ = concentricity
T = collapse
→ = coolant through jet hole



Concentricity and repeatability – concentricity see ☑ in chart/repeatability 6µm, i.e. system accuracy ≤ 10µm with standard precision collet chucks

Application – for HSC and for high precision work with inner coolant supply, but not with HPplus and Centro P collet chucks

Collapse – h8, i.e. only nominal size can be clamped

Special features – with seals for inner coolant supply (can be used up to 120 bar) and additional jet hole to bring the coolant to the cutting edge in tools without coolant channel

Remark – shanks with lateral flat can be used only qualified, i.e. the flat must be behind the rubber seals in order to reach a complete sealing

E-No. Description	Order-No.	☑	T	D	L	P	Standard bore
☑ 425E GER16-DD	13441	6µm	h8	16,7	27,5	●	4,0•6,0
☑ 427E GER20-DD	13442	6µm	h8	20,7	31,5	●	4,0•6,0•8,0
☑ 429E GER25-DD	13443	6µm	h8	25,7	34	●	4,0•6,0•8,0•10,0•12,0•14,0
☑ 469E GER32-DD	13444	6µm	h8	32,7	40	●	4,0•6,0•8,0•10,0•12,0•14,0•16,0•18,0•20,0

Use of shanks with lateral flat with forms D and DD –

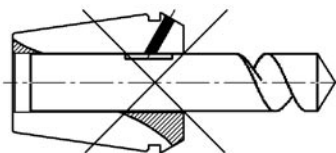

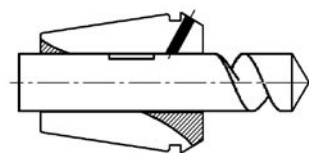

Incorrect position!



Correct position!

Also available – set of coolant collets to DIN6499/ISO15488-A with seals for IC – form D in wooden boxes

E-No. Description	Order-No.	Set		P	Content of set
④ 425E GER16-D	1340116	5teilig	6µm	●	4,0•5,0•6,0•8,0•10,0
④ 427E GER20-D	1340216	5teilig	6µm	●	4,0•6,0•8,0•10,0•12,0
④ 429E GER25-D	1340316	6teilig	6µm	●	4,0•6,0•8,0•10,0•12,0•16,0
④ 469E GER32-D	1340416	6teilig	6µm	●	6,0•8,0•10,0•12,0•16,0•20,0

Concentricity and repeatability – concentricity to DIN/ISO class 1 see  in chart/repeatability 6µm

Application – for tapping, but not with HPplus and Centro P collet chucks

Collapse – h8, i.e. only nominal size can be clamped

Special features – with internal square drive without axial compensation, since this is not necessary for rigid tapping

Remark – chart with tap shank dimensions DIN and ISO see pages 42 and 43 in the appendix • for the same shank-Ø the DIN as well as the ISO taps can be used

E-No. Description	Order-No.		D	L	L2	P	Standard bore (shank-Ø/square)
④ 4016E GER11-GB	13100	10µm	11,3	18	12	●/■	2,5/2,1•2,8/2,1
						●/■	3,5/2,7•4,0/3,2•4,5/3,55•5,0/4,0•5,5/4,5•6,0/5,0
④ 4031E GER16-GB	13101	10µm	16,7	27,5	18	●/■	2,8/2,1
						●/■	3,5/2,7•4,0/3,2•4,5/3,55•5,0/4,0•5,5/4,5•6,0/5,0•6,3/5,0•7,0/5,6•7,1/5,6
					22	●/■	8,0/6,3
						18	●/■
④ 4276E GER20-GB	13102	10µm	20,7	31,5	18	●/■	3,5/2,7•4,0/3,2•4,5/3,55•5,0/4,0•5,5/4,5•6,0/5,0•6,3/5,0•7,0/5,6•7,1/5,6
					22	●/■	8,0/6,3•9,0/7,1
		15µm			25	●/■	10,0/8,0•11,0/9,0•11,2/9,0
④ 4282E GER25-GB	13103	10µm	25,7	34	18	●/■	3,5/2,7•4,0/3,2•4,5/3,55•5,0/4,0•5,5/4,5•6,0/5,0•6,3/5,0•7,0/5,6•7,1/5,6
					22	●/■	8,0/6,3•9,0/7,1
		15µm			25	●/■	10,0/8,0•11,0/9,0•11,2/9,0•12,0/9,0•12,5/10,0•14,0/11,2•16,0/12,5
④ 4537E GER32-GB	13104	10µm	32,7	40	18	●/■	4,0/3,2•4,5/3,55•5,0/4,0•5,5/4,5•6,0/5,0•6,3/5,0•7,0/5,6•7,1/5,6
					22	●/■	8,0/6,3•9,0/7,1
		15µm			25	●/■	10,0/8,0•11,0/9,0•11,2/9,0•12,0/9,0•12,5/10,0•14,0/11,2•16,0/12,5
					30	●/■	18,0/14,5•20,0/16,0
④ 4716E GER40-GB	13105	10µm	40,7	46	18	●/■	6,0/5,0•6,3/5,0•7,0/5,6•7,1/5,6
					22	●/■	8,0/6,3•9,0/7,1
		15µm			25	●/■	10,0/8,0•11,0/9,0•11,2/9,0•12,0/9,0•12,5/10,0•14,0/11,2•16,0/12,5
					33	●/■	18,0/14,5•20,0/16,0•22,0/18,0•25,0/20,0

Type GER-D

Sets in Wooden Boxes – form D



Type GER-GB

Tap Collets DIN6499/ISO15488-A with Internal Square Drive – form GB

10µm at GB!

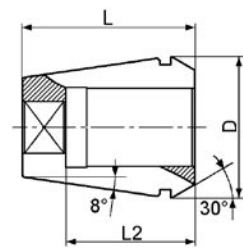

 = concentricity



Type ET

PCM® Tap Collets interchangeable DIN6499/ISO15488 with Incorporated Axial Compensation – form ET

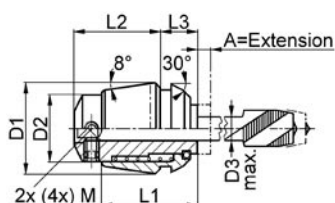

= concentricity



Concentricity and repeatability – concentricity to DIN/ISO class 2 see in chart/repeatability 10µm

Application – for tapping, but not with HPplus and Centro P chucks

Collapse – h7, i.e. only nominal size can be clamped

Special features – compact and very strong construction • incorporated axial compensation • rational and economic solution for tapping on CNC machines • spring force is adapted to the corresponding tap size • for heavy tapping operations please use clamping nut type B or nut with slide bearing

Remark – chart with tap shank dimensions DIN and ISO see pages 42 and 43 in the appendix • for the same shank-Ø the DIN as well as the ISO taps can be used

E-No. Description	Order-No.		P	Standard bore
4013E ET-1-11	13120	15µm	●	1,4•1,6•1,8•2,0•2,2•2,24•2,5•2,8•3,0•3,15•3,5•3,55
4033E ET-1-16	13121	15µm	●	1,4•1,6•1,8•2,0•2,2•2,24•2,5•2,8•3,0•3,15•3,5•3,55•4,0•4,5•5,0•5,5•5,6•6,0•6,2•6,3
4284E ET-1-20	13122	15µm	●	2,2•2,24•2,5•2,8•3,0•3,15•3,5•3,55•4,0•4,5•5,0•5,5•5,6•6,0•6,2•6,3•7,0
4285E ET-1-25	13123	15µm	●	2,5•2,8•3,0•3,15•3,5•3,55•4,0•4,5•5,0•5,5•5,6•6,0•6,2•6,3•7,0•7,1•8,0•8,5•9,0•10,0
4538E ET-1-32	13124	15µm 20µm	● ●	4,5•5,0•5,5•5,6•6,0•6,2•6,3•7,0•7,1•8,0•8,5•9,0•10,0 10,5•11,0•11,2•12,0•12,5
4717E ET-1-40	13125	15µm 20µm	● ●	6,0•6,2•6,3•7,0•7,1•8,0•8,5•9,0•10,0 10,5•11,0•11,2•12,0•12,5•14,0•15,0•16,0•17,0
4774E ET-1-50	13126	20µm	●	10,5•11,0•11,2•12,0•12,5•14,0•15,0•16,0•17,0•18,0•19,0•20,0•22,0•22,4

Technical Data

Description	A	D1	D2	D3 max.	L1	L2	L3
ET-1-11	5,5	11,5	7	3,55	18	16,5	5
ET-1-16	7	17	11	6,3	22	20	7
ET-1-20	7	21	14	7,1	24	23	8
ET-1-25	8	26	19	10	26	24	10
ET-1-32	10	33	23	12,5	33	32	11
ET-1-40	13	41	28	17	42	42	12
ET-1-50	18	51	36	22	57	53	18

Operating instructions:

The tapping collets have an extension stroke, but no compression stroke.

They are made with a plain external body, one bored sleeve to hold the tap shank, 2 or 4 clamping screws on the tap square and one return spring.

On CNC machines the following tapping process is recommended:

Fast approach then tapping feed from 95 to 99% of the pitch value so as to be in the compensation stroke when spindle rotation and feed movement are simultaneously reversed. Use standard canned cycles.

Type KW-ER

Taper Wipers for Collet Closing Tapers DIN6499/ISO15488 (ER/ESX)



Application – for cleaning of the collet closing taper of HPplus Centro P collet chucks or standard collet chucks resp. collet holders

Description	Order-No.	for chucks and holders type
KW-ER16	22316	HP16•CP16•CPC16•HFER16•DHER16•GBH16•DGBH16•PHER16
KW-ER20	22320	HFER20•DHER20•GBH20•PHER20
KW-ER25	22325	HP25•CP25•NCER25•HFER25•DHER25•GBH25•PHER25
KW-ER32	22332	HP32•CP32•NCER32•HFER32•GBH32•PHER32
KW-ER40	22340	HP40•NCER40•HFER40

Concentricity and repeatability – extremely high due to the fact that the thread and taper are ground in one operation

Application – for all collet chucks, collet holders and acceptances DIN6499/ISO15488 (ER/ESX)

Special features – are indicated at every specific type

Execution type B – for tools, which have to be clamped with increased clamping force • more tenacious and harder because of a special heat treatment • unchanged mass, protection against corrosion and lower friction are additional advantages compared to the standard execution • the low friction takes effect in the thread as well as at the 30° cone of the collet and results in an approx. 50% higher clamping force • type B nuts are not recommend for high precision applications

Execution – with hexagon head (form D) • case-hardened (56-60 HRC) and burnished

Special features – all collets with outside form DIN6499/ISO15488 can be clamped • also available in type B

Description	Order-No.	max. torque	max. r.p.m.	D	L	G
STM11D	22601	25 Nm	7.000	19	12	M14x0,75
STM12D	22609	25 Nm	7.000	19	12	M14x0,75
STM16D *	22602	50 Nm	7.000	28	18	M22x1,5
STM20D *	22603	75 Nm	6.000	34	19,5	M25x1,5
STM11D-B	22401	25 Nm	7.000	19	12	M14x0,75
STM12D-B	22409	25 Nm	7.000	19	12	M14x0,75
STM16D-B	22402	50 Nm	7.000	28	18	M22x1,5
STM20D-B	22403	75 Nm	6.000	34	19,5	M25x1,5

* also available in a low cost K2 execution for applications where concentricity and life time of cutting tool are unimportant

Execution – with six slots (form E) • case-hardened (56-60 HRC) and burnished

Special features – pre-balanced for higher speed • all collets with outside form DIN6499/ ISO15488 can be clamped • also available in type B

Description	Order-No.	max. torque	max. r.p.m.	D	L	G
STM16E-G	22632	50 Nm	15.000	32	18	M22x1,5
STM20E-G	22633	75 Nm	15.000	35	19	M25x1,5
STM25E-G *	22634	85 Nm	15.000	42	21	M32x1,5
STM32E-G *	22635	105 Nm	15.000	50	23	M40x1,5
STM40E-G *	22636	150 Nm	15.000	63	26	M50x1,5
STM50E-G	22637	200 Nm	10.000	78	35	M64x2
STM16E-G-B	22412	50 Nm	15.000	32	18	M22x1,5
STM20E-G-B	22413	75 Nm	15.000	35	19	M25x1,5
STM25E-G-B	22414	85 Nm	15.000	42	21	M32x1,5
STM32E-G-B	22415	105 Nm	15.000	50	23	M40x1,5
STM40E-G-B	22416	150 Nm	15.000	63	26	M50x1,5
STM50E-G-B	22417	200 Nm	10.000	78	35	M64x2

* also available in a low cost K2 execution for applications where concentricity and life time of cutting tool are unimportant

Type STMD

Clamping Nuts DIN6499/ISO15488

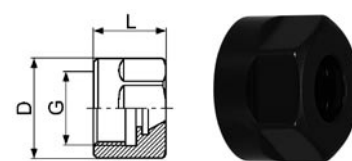

Type STME

Clamping Nuts DIN6499/ISO15488 for Higher Speed



Type GMER

High Speed Clamping Nuts with Slide Bearing

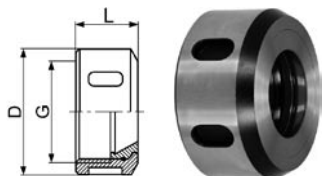

Execution – with special slots • case-hardened (56-60 HRC)

Special features – equipped with a precise and wear resistant slide bearing (except GMER11-HG, which are one-piece) • for high speed • completely ground • collets form D, DD, GB and ET can not be clamped • clamping range is only 0,5 mm, we recommend to clamp collets only with nominal size

Description	Order-No.	max. torque	max. r.p.m.	D	L	G
GMER11-HG	22731	25 Nm	70.000	19	11,8	M14x0,75
GMER16-HG	22732	50 Nm	65.000	32	18	M22x1,5
GMER20-HG	22733	75 Nm	60.000	35	19,5	M25x1,5
GMER25-HG	22734	85 Nm	55.000	42	20,5	M32x1,5
GMER32-HG	22735	105 Nm	20.000	50	23	M40x1,5

Type STMM

Mini Clamping Nuts

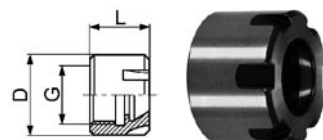

Execution – extremely small external dimensions • case-hardened (40-42 HRC at STM8M and 50-54 HRC at the other types)

Application – mainly used in multi-spindle drilling heads and cylindrical collet holders

Special features – ground all over and suitable for higher speed • for highest speed a balanced execution can be delivered • all collets with outside form DIN6499/ISO15488 can be clamped

Remark – not interchangeable with clamping nuts DIN6499/ISO15488 (different thread)

Description	Order-No.	max. torque	max. r.p.m.	D	L	G
STM8M	22620	8 Nm	70.000	12	11	M10x0,75
STM11M	22621	18 Nm	30.000	16	12	M13x0,75
STM16M	22622	28 Nm	20.000	22	18	M19x1
STM20M	22623	35 Nm	10.000	28	19,5	M24x1
STM25M	22624	40 Nm	8.000	35	21	M30x1

Type STMA

Clamping Nuts with External Thread

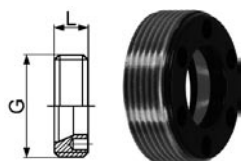

Execution – with external thread • case-hardened (56-60 HRC) and burnished

Application – in recessed collet mounts, such as driven tools, floating bushes and all space saving constructions

Special features – all collets with outside form DIN6499/ISO15488 can be clamped

Remark – not interchangeable with clamping nuts DIN6499/ISO15488 (external thread)

Description	Order-No.	max. torque	max. r.p.m.	L	G
STM11A	22661	24 Nm	7.000	6	M18x1
STM16A	22662	35 Nm	7.000	8	M24x1
STM20A	22663	40 Nm	6.000	11	M28x1,5
STM25A	22664	46 Nm	6.000	12,5	M32x1,5
STM32A	22665	60 Nm	5.000	14	M40x1,5

Execution – with six slots (form E) • case-hardened (56-60 HRC) and burnished

Special features – can be used up to 80 bar with seals HPDI • reasonable alternative compared to other sealing systems • pre-balanced for higher speed • all collets with outside form DIN6499/ISO15488 can be clamped • also available in type B

Description	Order-No.	max. torque	max. r.p.m.	D	L	G
STM16E-HPDI	22652	50 Nm	15.000	32	22	M22x1,5
STM20E-HPDI	22653	75 Nm	15.000	35	23,2	M25x1,5
STM25E-HPDI	22654	85 Nm	15.000	42	24,7	M32x1,5
STM32E-HPDI	22655	105 Nm	15.000	50	27	M40x1,5
STM40E-HPDI	22656	150 Nm	15.000	63	30,7	M50x1,5
STM16E-HPDI-B	22422	50 Nm	15.000	32	22	M22x1,5
STM20E-HPDI-B	22423	75 Nm	15.000	35	23,2	M25x1,5
STM25E-HPDI-B	22424	85 Nm	15.000	42	24,7	M32x1,5
STM32E-HPDI-B	22425	105 Nm	15.000	50	27	M40x1,5
STM40E-HPDI-B	22426	150 Nm	15.000	63	30,7	M50x1,5

Execution – extremely small external dimensions • case-hardened (50-54 HRC)

Application – mainly used in multi-spindle drilling heads and cylindrical collet holders

Special features – can be used up to 80 bar with seals HPDI • reasonable alternative compared to other sealing systems • ground all over and suitable for higher speed • all collets with outside form DIN6499/ISO15488 can be clamped

Remark – not interchangeable with clamping nuts DIN6499/ISO15488 (different thread)

Description	Order-No.	max. torque	max. r.p.m.	D	L	G
STM16M-HPDI	22642	28 Nm	20.000	22	22	M19x1
STM20M-HPDI	22643	35 Nm	10.000	28	23,2	M24x1
STM25M-HPDI	22644	40 Nm	8.000	35	24,7	M30x1

Execution – vulcanised seal can be used up to 80 bar

Special features – collapse 0,5 mm (+0,4/-0,1)

Description	Order-No.	D	L	P	from-to	steps	collapse
HP16-DI	2430301	12,6	2	●	1,0-2,5	0,5	+0,4/-0,1
				●	3,0-10,0	0,5	
				●	1/8"•3/16"•1/4"•5/16"•3/8"		
HP20-DI	2440301	15,8	2	●	2,0-2,5	0,5	+0,4/-0,1
				●	3,0-13,0	0,5	
				●	1/8"•3/16"•1/4"•5/16"•3/8"•1/2"•5/8"•3/4"		
HP25-DI	2450301	20,2	2	●	2,0-2,5	0,5	+0,4/-0,1
				●	3,0-16,0	0,5	
				●	2,0-2,5	0,5	
HP32-DI	2460301	26,2	2	●	3,0-20,0	0,5	+0,4/-0,1
				●	2,0-2,5	0,5	
				●	1/8"•3/16"•1/4"•5/16"•3/8"•1/2"•5/8"•3/4"		
HP40-DI	2470301	34,2	2	●	3,0-30,0	0,5	+0,4/-0,1
				●	1/8"•3/16"•1/4"•5/16"•3/8"•1/2"•5/8"•3/4"•7/8"•1"		

Type STME-HPDI

Clamping Nuts DIN6499/ISO15488 for Seals HPDI

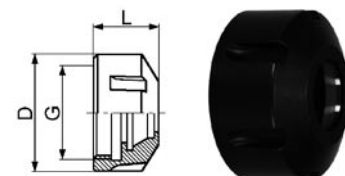

Type STMM-HPDI

Mini Clamping Nuts for Seals HPDI

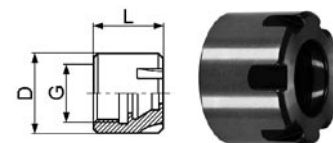

Type HPDI

Seals

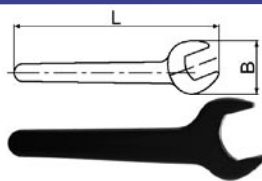

Type SCHL-SW
Wrenches for Clamping Nuts with Hexagon Head

Application – for clamping nuts DIN6499/ISO15488-D with hexagon head (form D)

Special features – specific coating of the wrench

Description	Order-No.	L	B	for clamping nuts
SCHL-SW17	22801	155	38	STM11D•STM12D
SCHL-SW25	22802	218	53	STM16D
SCHL-SW30	22803	265	61	STM20D

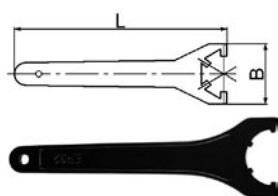
Type SCHL-E
Wrenches for Clamping Nuts with six Slots

Application – for clamping nuts DIN6499/ISO15488-D with six slots (form E)

Special features – specific coating of the wrench

Description	Order-No.	L	B	for clamping nuts
SCHL-STM16E	22812	163	50	STM16E
SCHL-STM20E	22813	180	60	STM20E
SCHL-STM25E	22804	210	65	STM25E
SCHL-STM32E	22805	253	75	STM32E
SCHL-STM40E	22806	290	88	STM40E
SCHL-STM50E	22807	350	110	STM50E

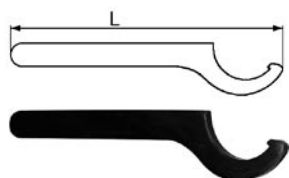
Type SCHL-GR
Wrenches for Clamping Nuts with special Slots

Application – for high speed clamping nuts with special slots

Special features – with hook nose DIN1810-A

Description	Order-No.	L	for clamping nuts
SCHL-GR.16-20	21409	110	GMER11-HG
SCHL-GR.30-32	21408	136	GMER16-HG
SCHL-GR.34-36	21406	170	GMER20-HG
SCHL-GR.40-42	21411	170	GMER25-HG
SCHL-GR.45-50	21401	206	GMER32-HG

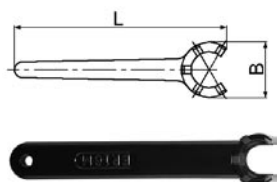
Type SCHL-M
Wrenches for Mini Clamping Nuts

Application – for mini nuts

Special features – specific coating of the wrench

Description	Order-No.	L	B	for clamping nuts
SCHL-STM8M	22820	76	13	STM8M
SCHL-STM11M	22821	95,5	17	STM11M
SCHL-STM16M	22822	117	22,5	STM16M
SCHL-STM20M	22823	128	28	STM20M
SCHL-STM25M	22824	145	36	STM25M

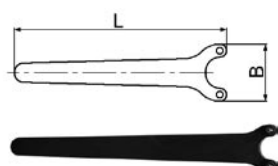
Type SCHL-A
Wrenches for Clamping Nuts with External Thread

Application – for clamping nuts with external thread

Description	Order-No.	L	B	for clamping nuts
SCHL-STM11A	22841	115	22	STM11A
SCHL-STM16A	22842	140	26	STM16A
SCHL-STM20A	22843	160	28	STM20A
SCHL-STM25A	22844	160	32	STM25A
SCHL-STM32A	22845	180	41	STM32A

Since January 2002 all new series of  collets to DIN6388, as well as the collets to DIN6499/ISO15488 (ER/ESX), are manufactured with the **super-finished surface $\leq 1,0\mu\text{m}$** . The advantages of this execution are as follows: **improved grip • increased rigidity and clamping force • higher precision and system concentricity • enhanced resistance to corrosion**

Execution – interchangeable with collets to DIN6388/ISO10897 (OZ) form A, but because of the special construction they have decisive advantages • 4 slots from each end ensure the bore lies exactly on the shank diameter • a longer clamping length results in higher clamping forces and due to the precise axial clamping, to a better concentricity • the altogether higher system rigidity is ideal for High Speed Milling

Execution to DIN-A

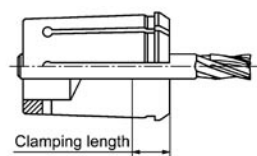

Improved execution FAHRION



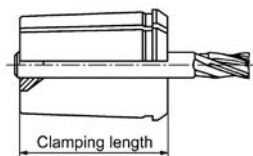

- better concentricity (axially parallel clamping in bore, no twisting)
- higher clamping force (due to longer supported length)
- higher system rigidity (ideal for High Speed Milling)
- longer tool life







Concentricity and repeatability – concentricity see  in chart/repeatability $6\mu\text{m}$, i.e. system accuracy $\leq 10\mu\text{m}$ with standard precision collet chucks and $6\mu\text{m}$ collets

Application – for HSC and for high precision work

Collapse – h10, i.e. only nominal size can be clamped

E-No. FM-No.	Order-No.		T	D	L	P	from-to	steps
 410E FM16	12005	$6\mu\text{m}$	h10	25,2	40	●	2,0-16,0	0,5
 444E FM25	12007	$6\mu\text{m}$	h10	34,8	52	●	2,0-25,0	1,0
 450E FM32	12008	$10\mu\text{m}$	h10	43,5	60	●	4,0-32,0	1,0

Also available – sets of collets to DIN6388/ISO10897 (OZ) – form A8 in wooden boxes without milling chuck and clamping wrench

E-No. FM-No.	Order-No.	Set		P	Content of set
 410E FM16	1200516	16 pieces	$6\mu\text{m}$	●	2,0-16,0/1,0 std. + 2,5
 444E FM25	1200716	15 pieces	$6\mu\text{m}$	●	5,0-16,0/1,0 std. + 18,0•20,0•25,0
 450E FM32	1200816	16 pieces	$10\mu\text{m}$	●	5,0-16,0/1,0 std. + 18,0•20,0•25,0•32,0

Type HF-A8

**Precision Collets
DIN6388/ISO10897 (OZ) –
form A8 (8 slots) –
interchangeable with DIN**

$6\mu\text{m}$ at A8!

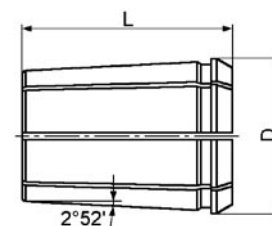

 = concentricity

T = collapse



**Sets in Wooden Boxes –
form A8**



Type HF-A6

**Collets DIN6388/
ISO10897-A (OZ) –
form A6**

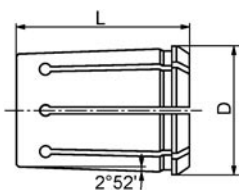

☑ = concentricity
T = collapse



Concentricity and repeatability – concentricity to DIN class 2 see ☑ in chart/repeatability 10µm

Application – for standard-collet chucks and holder

Collapse – h7, i.e. only nominal size can be clamped

E-No. FM-No.	Order-No.	☑	T	D	L	P	from-to	steps
400E FM6	12001	15µm	h7	11,5	21	●	1,0-6,0	0,5
						●	1/8"•1/4"	
401E FM8	12002	15µm	h7	14,5	26	●	1,0-8,0	0,5
						●	1/8"•1/4"	
404E FM10	12003	15µm	h7	17,2	30	●	1,0-10,0	0,5
						●	1/8"•1/4"	
407E FM12	12004	15µm	h7	19,8	34	●	1,0-10,0	0,5
		20µm				●	11,0-12,0	0,5
		15µm				●	1/8"•1/4"	

Type RT

**PCM® Tap Collets
interchangeable DIN6388/
ISO10897-A (OZ)
with Incorporated Axial
Compensation – form RT**

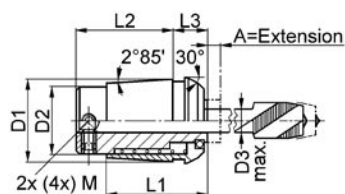

☑ = concentricity



Concentricity and repeatability – concentricity to DIN class 2 see ☑ in chart/repeatability 10µm

Application – for tapping

Collapse – h7, i.e. only nominal size can be clamped

Special features – compact and very strong construction • incorporated axial compensation • rational and economic solution for tapping on CNC machines • spring force is adapted to the corresponding tap size

Remark – chart with tap shank dimensions DIN and ISO see pages 42 and 43 in the appendix • for the same shank-Ø the DIN as well as the ISO taps can be used

E-No Description	Order-No.	☑	P	Standard bore
4109E FM16RT-1-63	12125	15µm	●	2,5•2,8•3,0•3,15•3,5•3,55•4,0•4,5•5,0•5,5•5,6•6,0•6,2•6,3•7,0•7,1•8,0•8,5•9,0•10,0
4545E FM25RT-1-65	12127	15µm	●	6,0•6,2•6,3•7,0•7,1•8,0•8,5•9,0•10,0
		20µm	●	10,5•11,0•11,2•12,0•12,5•14,0•15,0•16,0•17,0

Technical Data

Description	replaces	A	D1	D2	D3 max.	L1	L2	L3
FM16RT-1-63	410E/415E	8	22,65	19	10	26	22	12,5
FM25RT-1-65	444E/462E	13	32,9	28	16	40	38	14

Operating instructions:

The tapping collets have an extension stroke, but no compression stroke.

They are made with a plain external body, one bored sleeve to hold the tap shank, 2 or 4 clamping screws on the tap square and one return spring.

On CNC-machines the following tapping process is recommended:

Fast approach then tapping feed from 95 to 99% of the pitch value so as to be in the compensation stroke when spindle rotation and feed movement are simultaneously reversed. Use standard canned cycles.

Concentricity and repeatability – concentricity see  in chart/repeatability 6µm, i.e. system accuracy ≤ 10µm with standard precision collet chucks and 6µm collets

Application – for HSC and for high precision work

Collapse – nominal size reduced by T

Special features – double slotted (10 slots up to Ø 10,0 mm and 12 slots for larger Ø) with 0,5 mm collapse for clamping cylindrical shanks and twist drills on their lands

E-No. FM-No.	Order-No.		T	D	L	P	from-to	steps
® 415E FM16DG	12201	6µm	-0,5	25,5	40	●	2,0-16,0	0,5
							2,0-25,0	0,5
® 462E FM25DG	12202	6µm	-0,5	35,05	52	●	1/8"•1/4"•3/8"•1/2"•5/8"•3/4"•1"	
® 467E FM32DG	12203	10µm	-0,5	43,7	60	●	4,0-32,0	0,5
® 468E FM40DG	12204	15µm	-0,5	52,2	68	●	12,0-40,0	0,5

Type HF-DG

Precision Collets
DIN6388/ISO10897-B (OZ)
(double slotted) – form B

6µm bei B!

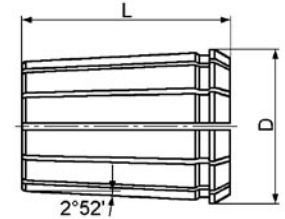

 = concentricity
T = collapse



Concentricity and repeatability – concentricity to DIN class 2 see  in chart/repeatability 10µm

Application – use only, if concentricity and life time of cutting tool are unimportant

Collapse – nominal size reduced by T

Special features – double slotted with 0,5 mm collapse for clamping cylindrical shanks and twist drills on their lands

E-No. FM-No.	Order-No.		T	D	L	P	from-to	steps
415E FM16DG-K2	12401	15µm	-0,5	25,5	40	●	2,0-16,0	0,5
							2,0-10,0	0,5
4541E FM20DG-K2	12407	20µm	-0,5	29,8	45	●	10,5-20,0	0,5
							2,0-10,0	0,5
462E FM25DG-K2	12402	15µm	-0,5	35,05	52	●	10,5-25,0	0,5
							4,0-10,0	0,5
467E FM32DG-K2	12403	20µm	-0,5	43,7	60	●	10,5-30,0	0,5
							30,5-32,0	0,5
							30,5-32,0	0,5

Type HF-K2

Collets
DIN6388/ISO10897-B (OZ)
(double slotted) – form K2

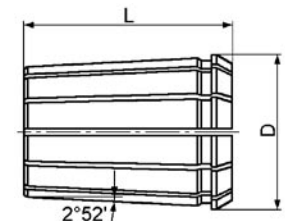

 = concentricity
T = collapse

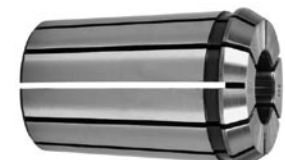

Type HF-C

**Collets
DIN6388/ISO10897 (OZ)
with Drawbolt Thread –
form C**

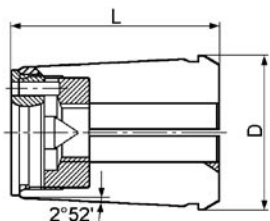

☑ = concentricity

T = collapse



Concentricity and repeatability – concentricity to DIN class 2 see ☑ in chart/repeatability 10µm

Application – for mills with drawbolt thread, Clarkson system

Collapse – h7, i.e. only nominal size can be clamped

E-No. FM-No.	Order-No.	☑	T	D	L	P	Standard bore
421E FM16G	12101	15µm	h7	25,2	40	●	6,0•8,0•10,0
		20µm					12,0•16,0
459E FM25G	12102	15µm	h7	34,8	52	●	6,0•8,0•10,0
		20µm					12,0•16,0•20,0•25,0
460E FM32G	12103	15µm	h7	43,5	60	●	6,0•8,0•10,0
		20µm					12,0•16,0•20,0•25,0
		30µm					32,0
461E FM40G	12104	20µm	h7	52,2	68	●	12,0•16,0•20,0•25,0
		30µm					32,0

Type KM

**Clamping Nuts
DIN6388/ISO10897-D (OZ)
with Ball Bearing Ring**

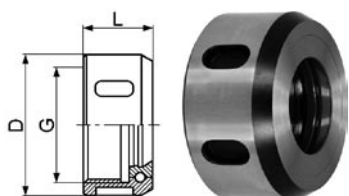

Concentricity and repeatability – extremely high due to the fact that the nuts are ground with the ball bearing ring in one operation

Application – for all collet chucks, collet holders and acceptances DIN6388/ISO10897 (OZ)

Special features – high clamping forces due to ball bearing from KM216 on • clamping nuts marked with * are one-piece, i.e. they have no ball bearing ring

Description	Order-No.	max. torque	max. r.p.m.	D	L	G
KM106-FM6 *	21507	30 Nm	60.000	18	14,3	M14x1
KM108-FM8 *	21508	45 Nm	40.000	26	19	M20x1,5
KM110-FM10 *	21509	50 Nm	40.000	30	19	M22x1,5
KM112-FM12 *	21510	70 Nm	40.000	35	20	M27x1,5
KM216-FM16	21501	85 Nm	12.000	43	24	M33x1,5
KM220-FM20	21511	105 Nm	10.000	50	28	M42x2
KM225-FM25	21502	140 Nm	8.000	60	30	M48x2
KM432-FM32	21503	170 Nm	5.000	72	33,5	M60x2,5
KM640-FM40	21504	185 Nm	4.000	85	37	M68x2,5

Type SCHL

**Wrenches for
Clamping Nuts DIN6388/
ISO10897-D (OZ)**

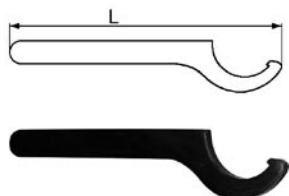

Application – for clamping nuts DIN6388/ISO10897-D (OZ)

Special features – with hook nose DIN1810-A

Description	Order-No.	L	for clamping nuts
SCHL-GR.16-20	21409	110	KM106-FM6
SCHL-GR.25-28	21410	136	KM108-FM8
SCHL-GR.30-32	21408	136	KM110-FM10
SCHL-GR.34-36	21406	170	KM112-FM12
SCHL-GR.45-50	21401	206	KM216-FM16•KM220-FM20
SCHL-GR.58-62	21402	240	KM225-FM25
SCHL-GR.68-75	21403	240	KM432-FM32
SCHL-GR.80-90	21404	280	KM640-FM40

Application – for collet holders and –chucks for system Erickson DA/DK

Collapse – nominal size reduced by T

Special features – extremely small external dimensions • not an accurate clamping system

E-No. FM-No. Description	Order- No.	T	D	D1	L	P	from-to	steps
416E FM4513 DK/DA300	13501	-0,5	9,5	7,62	25,5	●	1,0-6,5	0,5
417E FM4377 DK/DA200	13502	-0,5	13,6	11,43	30,4	●	1,0-10,0	0,5
418E FM4377/2 DK/DA100	13503	-0,5	19,47	16,51	36,7	●	2,0-14,5	0,5
419E FM4696 DK/DA180	13504	-0,5	26,04	22,08	41,7	●	2,0-20,0	0,5

Execution – short with hexagon head

Application – for double angle collets DK/DA

Description	Order- No.	A/F	D	L
STMDA300	21902	17	19	18
STMDA200	21903	24	27	20
STMDA100	21904	32	35	25
STMDA180	21905	41	45	23

Execution – long and slim with hexagon head

Application – for double angle collets DK/DA

Description	Order- No.	A/F	D	L
STMDA300-S	21912	13	14	28
STMDA200-S	21913	19	21	38
STMDA100-S	21914	24	27	40
STMDA180-S	21915	32	37	42

Type DK/DA

Erickson Double Angle Collets DK/DA

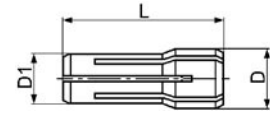

T = collapse



Type STMDA

Erickson Clamping Nuts DK/DA – short

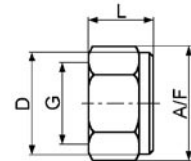

Type STMDAS

Erickson Clamping Nuts DK/DA – long

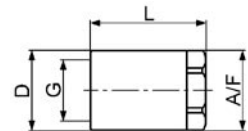

Type DF/TG

Erickson Collets DF/TG

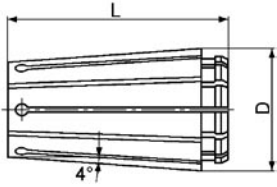

T = collapse

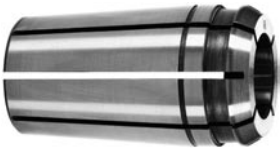

Application – for collet holders and –chucks for system Erickson DF/TG

Collapse – nominal size reduced by T

E-No. FM-No. Description	Order-No.	T	D	L	P	from-to	steps
420E FM5062 DF/TG75	13602	-0,5	27	46,83	●	3,0-20,0	0,5
464E FM5063 DF/TG100	13603	-0,5	35,03	60,4	●	6,0-25,5	0,5

Type STMTG

Erickson Clamping Nuts DF/TG



Execution – with ball bearing ring

Application – for collets DF/TG

Description	Order-No.	D	L	G
STMTG75	21952	46	24	1.7/8" x 12 Acme
STMTG100	21953	60	30	1.1/2" x 12 Acme

Type HX

Collets with Hexagon Head

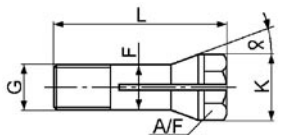

Application – for multi-spindle drill heads

Collapse – h7, i.e. only nominal size can be clamped

Special features – with hexagon head (special executions see table below)

E-No. FM-No.	Order-No.	F	K	L	α	A/F	P	from-to	steps
6023E FM979e	10626	5	6,5	20	20°	5,5	●	1,0-3,0	0,5
		G	M5x0,6						
6043E FM980e	10627	6	8,5	25,5	20°	6,5	●	1,0-4,0	0,5
		G	M6x0,7						
600E FM832	10601	6	8,6	28,5	10°	7	●	1,0-4,0	0,5
		G	M6x0,75						
601E FM833	10602	8	11	33	10°	9	●	1,0-6,0	0,5
		G	M8x0,75						
603E FM981/e	10620	8	11,5	30,5	20°	9	●	1,0-6,0	0,5
		G	M8x0,85						
6314E FM4135	10621	10	14	34	15°	11	●	1,0-8,0	0,5
		G	M10x0,75						
635E FM4239	10625	12	18	34	15°	14	●	1,0-10,0	0,5
		G	M12x0,75						

All above mentioned collets are deliverable in the following special executions

- with intermediate diameters (steps of 0,1 mm)
- with internal square drive for taps
- with inner thread for stop screws

Application – for clamping cylindrical twist drills with tangs and counterbores in tool adaptors E-MK (see catalogue Workpiece Clamping, Tapping Attachments, Quick Change Chucks page 22), automotive shanks and other Morse taper acceptances

Collapse – h7, i.e. only nominal size can be clamped

E-No. FM-No.	Order-No.	MT X	K	L	P	from-to	steps
510E FM500/0	10501	0	9,2	59,5	●	1,5-5,5	0,1
511E FM500/1	10502	1	12,2	65,5	●	3,0-8,0	0,1
514E FM500/2	10503	2	18	80	●	5,0-13,0	0,1
545E FM500/3	10504	3	24,1	99	●	8,0-18,0	0,5
548E FM500/4	10505	4	31,6	124	●	12,0-20,0	1,0
599E FM500/5	10506	5	44,7	156	●	20,0-36,0	1,0

Application – for clamping cylindrical taps with driving square in tap adaptors GE-MK (see catalogue Workpiece Clamping, Tapping Attachments, Quick Change Chucks page 24), automotive shanks and other Morse taper acceptances

Collapse – h7, i.e. only nominal size can be clamped

E-No. FM-No.	Order-No.	MT X	K	L	P	Standard bore
500E FM501/0	10511	0	9,2	59,5	●	2,5•2,8•3,15•3,5•3,55•4,0•4,5
501E FM501/1	10512	1	12,2	65,5	●	2,5•2,8•3,15•3,5•3,55•4,0•4,5• 5,0•5,5•5,6•6,0•6,3•7,0•7,1•8,0
504E FM501/2	10513	2	18	80	●	4,5•5,0•5,5•5,6•6,0•6,3•7,0•7,1• 8,0•9,0•9,5•10,0•11,0•11,2• 12,0•12,5
535E FM501/3	10514	3	24,1	99	●	8,0•9,0•9,5•10,0•11,0•11,2• 12,0•12,5•14,0•16,0
538E FM501/4	10515	4	31,6	124	●	12,0•12,5•14,0•16,0•18,0•20,0• 22,0•22,4•25,0
589E FM501/5	10516	5	44,7	156	●	18,0•20,0•22,0•25,0•28,0•30,0• 31,5•32,0•36,0

Application – for clamping cylindrical tools

Collapse – h7, i.e. only nominal size can be clamped

Special features – Morse taper with internal draw-in thread

E-No. FM-No.	Order-No.	MT X	G	K	L	P	from-to	steps
503E FM521	10520	2	M10	18	69	●	3,0-14,0	1,0
536E FM522	10521	3	M12	24	85,5	●	3,0-18,0	1,0
539E FM523	10523	4	M16	31,5	108,5	●	4,0-24,0	1,0

Type SL-BO

Split Sleeves DIN6329

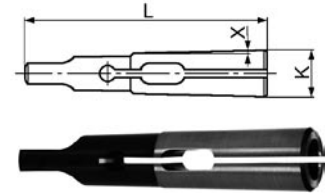

Type SL-GB

Split Sleeves DIN6328

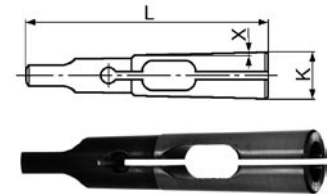

Type SH

Clamping Sleeves MT

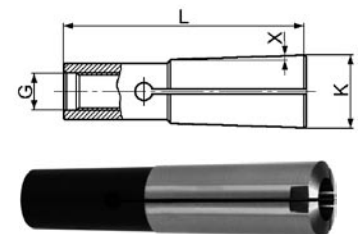

Type RFJ

Rubber-Flex® Collets

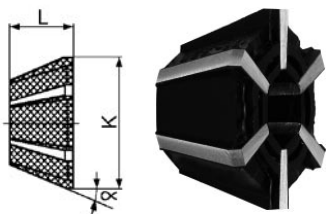

Application – in tapping holders, drill holders and acceptances DIN6345

Collapse – see T in chart

Special features – large capacity for tools with cylindrical shank • axially parallel clamping pressure along the entire bore length results in consistent concentricity within the whole clamping capacity • high radial clamping force • rubber is resistant against coolant and heat up to 100° C

E-No. Description	Order-No.	T	K approx.	L approx.	α	P	Clamping capacity		
710E RFJ115	10810	1,5				●	1,0-2,5		
710E RFJ116	10811	2,0	15	12	13°	●	2,5-4,5		
710E RFJ117	10812	3,0				●	4,5-6,5		
715E RFJ423	10801	2,5				●	2,0-4,5		
715E RFJ421	10803	3,0	23	12,7	20°	●	3,5-6,5		
715E RFJ420	10802	3,5				●	4,5-8,0		
715E RFJ422	10804					●	6,5-10,0		
750E RFJ444	10805	2,7	28	16	22°30'	●	1,8-4,5		
750E RFJ443	10806	4,2	30,5			●	2,8-7,0		
750E RFJ441	10813	5,5	31,5			●	4,5-10,0		
750E RFJ440	10807					●	7,0-13,0		
750E RFJ445 *	10814	6,0	32			●	9,0-15,0		
750E RFJ445/S1 *	10816					●	10,0-16,0		
766E RFJ460	10815	4,0				19	25°	●	6,0-10,0
766E RFJ461	10808	6,0	44					●	10,0-16,0
766E RFJ462	10809	7,0		●	16,0-23,0				

* can only be used in conjunction with special nut STM44S-RF44

Type STM

Rubber-Flex® Clamping Nuts



Application – for all tapping holders, drill holders and acceptances DIN6345

Description	Order-No.	D	L	G	for collets
STM11-RF11	22902	21	14	M16x1	710E
STM42-RF42	22904	31	17	M24x1,5	715E
STM44-RF44	22906	40	18	M32x1,5	750E
STM44S-RF44 *	22907				
STM46-RF46	22908	56,4	24,5	TR.1,850"x14	766E

* all collets RFJ44 can be used in the special nut for RFJ445

Type SCHL

Wrenches for Rubber-Flex® Clamping Nuts

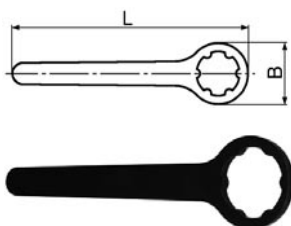

Application – for all clamping nuts for Rubber-Flex® collets

Special features – security ring wrench

Description	Order-No.	B	L	for clamping nuts
SCHL-STM11	22922	30	135	STM11
SCHL-STM42	22924	42	160	STM42
SCHL-STM44	22926	54	190	STM44•STM44S
SCHL-STM46	22928	89	215	STM46

Application – for holding tools with cylindrical shanks in collets DIN6499/ISO15488 (ER/ESX) on CNC lathes

Acceptance – cylindrical shank with flat • for internal coolant supply (axial or lateral)

Concentricity and repeatability – shank O.D. to collet closing taper $\leq 5\mu\text{m}$

Remark – collets, wrenches and nuts as spare parts see pages 6 to 16

Extend of delivery – with clamping nut DIN6499/ISO15488 (form E with six slots) and inner stop • without collets and wrenches

Description	Order-No.	L1	L2	D1	D2	G	Collets
NCER25-ZW32-L1=75	26562000075	75	20	32	42	M18	429E•430E
NCER25-ZW40-L1=80	26570000080	80	25	40			
NCER32-ZW32-L1=60	26662000060	60	39	32	50	M22	469E•470E
NCER32-ZW40-L1=80	26670000080	80	25	40			
NCER32-ZW45-L1=100	26675000100	100	36	45			
NCER32-ZW50-L1=120	26680000120	120	25	50			
NCER40-ZW32-L1=60	26762000060	60	57	32	63	M22	471E•472E
NCER40-ZW40-L1=75	26770000075	75	37	40		M24	
NCER40-ZW45-L1=100	26775000100	100	36	45			
NCER40-ZW50-L1=120	26780000120	120	27	50			

Application – on CNC lathes for holding tools with cylindrical shanks in collets DIN6499/ISO15488 (ER/ESX)

Acceptance – cylindrical shank DIN69880

Concentricity and repeatability – shank O.D. to collet closing taper $\leq 5\mu\text{m}$

Special features – coolant supply through collet (use either clamping nut HPDI with seals or collets GER-D)

Remark – collets, wrenches and nuts as spare parts see pages 6 to 16

Extend of delivery – with clamping nut DIN6499/ISO15488 (with hexagon head form D for HFER16 and 20 – rest form E with six slots) • without collets and wrenches

Description	Order-No.	L1	L2	D1	D2	D3	H	Collets
HFER16D-D16	26317	32	38	16	40	28	18	425E•426E
HFER16D-D20	26321	40	47	20	50		23	
HFER20D-D16	26417	32	42	16	40	34	18	427E•428E
HFER25D-D20	26521	40		20	50		23	429E•430E
HFER25D-D30	26531	55	53	30	68	42	28	
HFER25D-D40	26541	63		40	83		32	469E•470E
HFER32D-D20	26621	40		20	50		23	
HFER32D-D30	26631	55	60	30	68	50	28	471E•472E
HFER32D-D40	26641	63		40	83		32	
HFER40D-D30	26731	55	65	30	68	63	28	471E•472E
HFER40D-D40	26741	63		40	83		32	

Type NCER

Collet Holders with Cylindrical Shank and Flat for CNC Lathes

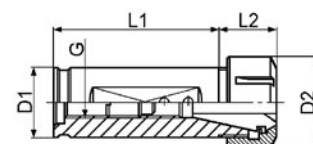

Type HFERD

VDI Collet Chucks with Shank DIN69880

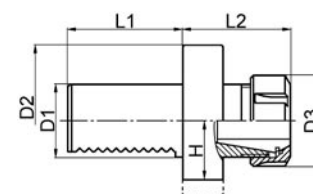

Type HFER

Collet Holders with Morse Taper Shank DIN228-A

Picture 1

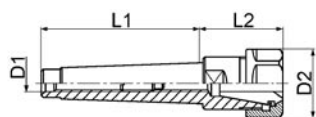

Picture 2

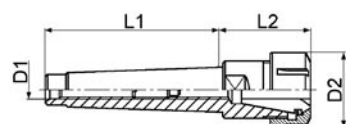

Application – for holding tools with cylindrical shanks in collets DIN6499/ISO15488 (ER/ESX)

Acceptance – Morse taper shank with draw-in thread DIN228-A • tang to modify the holder into execution DIN228-B on request

Concentricity and repeatability – outside taper to collet closing taper $\leq 5\mu\text{m}$

Remark – collets, wrenches and nuts as spare parts see pages 6 to 16

Extend of Delivery – with clamping nut DIN6499/ISO15488 (with hexagon head form D for HFER16 – rest form E with six slots) and inner stop • without collets and wrenches

Description	Order-No.	Pic.	MT	L1	L2	D1	D2	Collets
HFER11-MK1-M6	26201	1	1	52,5	23	M6	19	4008E
HFER16-MK1-M6	26301	1	1	52,5	41	M6	28	426E
HFER16-MK2-M10	26302		2	68	42	M10		
HFER16-MK3-M12	26303		3	85	37	M12		
HFER20-MK2-M10	26402	1	2	68	43	M10	34	428E
HFER25-MK2-M10	26502	2	2	68	47	M10	42	430E
HFER25-MK3-M12	26503		3	85		M12		
HFER32-MK2-M10	26602	2	2	68	60	M10	50	470E
HFER32-MK3-M12	26603		3	85	64	M12		
HFER32-MK4-M16	26604		4	108	54	M16		
HFER32-MK5-M20	26605		5	136	50	M20		
HFER40-MK3-M12	26703	2	3	85	64	M12	63	472E
HFER40-MK4-M16	26704		4	108	75	M16		
HFER40-MK5-M20	26705		5	136	82	M20		
HFER50-MK4-M16	26804	2	4	108	96	M16	78	477E
HFER50-MK5-M20	26805		5	136	91	M20		

Type HF

Collet Holders with Morse Taper Shank DIN228-A

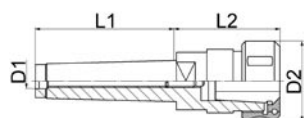

Application – for holding tools with cylindrical shanks in collets DIN6388/ISO10897 (OZ)

Acceptance – Morse taper shank with draw-in thread DIN228-A • tang to modify the holder into execution DIN228-B on request

Concentricity and repeatability – outside taper to collet closing taper $\leq 5\mu\text{m}$

Remark – collets, wrenches and nuts as spare parts see pages 17 to 20

Extend of delivery – with clamping nut DIN6388 with ball bearing ring • without collets and wrenches

Description	Order-No.	MT	L1	L2	D1	D2	Collets
HF216-MK2-M10	41002	2	68	65	M10	43	410E•415E•421E
HF216-MK3-M12	41003	3	85	61	M12		
HF216-MK4-M16	41004	4	108	45	M16		
HF216-MK5-M20	41005	5	136	33	M20		
HF225-MK2-M10	41402	2	68	76	M10	60	444E•462E•459E
HF225-MK3-M12	41403	3	85	80	M12		
HF225-MK4-M16	41404	4	108	84	M16		
HF225-MK5-M20	41405	5	136	60	M20		
HF432-MK4-M16	41804	4	108	91	M16	72	450E•467E•460E
HF432-MK5-M20	41805	5	136	85	M20		
HF640-MK4-M16	41904	4	108	114	M16	85	468E•461E
HF640-MK5-M20	41905	5	136		M20		

Application – on automatic lathes, capstan lathes and drill extensions for holding tools with cylindrical shanks in collets DIN6499/ISO15488 (ER/ESX)

Acceptance – cylindrical shank without flat

Concentricity and repeatability – shank O.D. to collet closing taper $\leq 5\mu\text{m}$

Remark – collets, wrenches and nuts as spare parts see pages 6 to 16 • other executions resp. shank with flat on request

Extend of delivery – with clamping nut DIN6499/ISO15488 (with hexagon head form D for HFER11 to 20 – rest form E with six slots) and inner stop (only for executions with internal thread) • without collets and wrenches

Description	Order-No.	Pic.	L1	L2	D1	D2	G	Collets	
HFER11-Z20-L1=60	26220000060	2	60	18	20	19	M7	4008E•4012E	
HFER11-Z25-L1=70	26225000070		70		25				
HFER11-Z1"-L1=75	26246000075	1	75	36	1"	-	-		
HFER16-Z10-L1=60	26310000060	1	60		10				
HFER16-Z12-L1=40	26312000040		40		12				
HFER16-Z14-L1=60	26314000060		60		14				
HFER16-Z16-L1=60	26316000060	-	60	16	M8	-	-		
HFER16-Z20-L1=50	26320000050			50				20	
HFER16-Z20-L1=100	26320000100	2	100	28	20	28	-	425E•426E	
HFER16-Z5/8"-L1=60	26342000060		60		5/8"				
HFER16-Z3/4"-L1=38	26344000038		38		3/4"				
HFER16-Z3/4"-L1=50	26344000050		50		3/4"				
HFER16-Z3/4"-L1=100	26344000100	-	100	22	1"	-	-	-	
HFER16-Z1"-L1=60	26346000060		60						1"
HFER16-Z1"-L1=75	26346000075	-	75	30	20	34	-	-	
HFER16-Z1"-L1=100	26346000100		100						1"
HFER20-Z20-L1=30	26420000030	2	30	37	20	34	M12	427E•428E	
HFER20-Z20-L1=50	26420000050		50		25		M14		
HFER20-Z25-L1=100	26425000100		100		27		M12		
HFER20-Z3/4"-L1=50	26444000050		50		37		M12		
HFER25-Z16-L1=100	26516000100	3	100	46	16	-	-	-	
HFER25-Z20-L1=50	26520000050		50		20				M12
HFER25-Z20-L1=100	26520000100	4	100	39	25	42	-	429E•430E	
HFER25-Z25-L1=50	26525000050		50		25				M18
HFER25-Z25-L1=100	26525000100		100		30				M14
HFER25-Z30-L1=60	26530000060		60		30				M18
HFER25-Z3/4"-L1=50	26544000050	-	50	45	3/4"	-	-	-	
HFER25-Z3/4"-L1=100	26544000100		100		3/4"				
HFER25-Z1"-L1=50	26546000050	-	50	39	1"	-	-	-	
HFER25-Z1"-L1=100	26546000100		100		1"				
HFER25-Z1.1/4"-L1=80	26548000080	-	80	25	1.1/4"	-	-	-	
HFER32-Z20-L1=50	26620000050		50		20				M12
HFER32-Z20-L1=100	26620000100	4	100	54	20	50	-	469E•470E	
HFER32-Z25-L1=50	26625000050		50		25				M18
HFER32-Z25-L1=100	26625000100		100		25				M20
HFER32-Z30-L1=60	26630000060		60		30				M22
HFER32-Z32-L1=60	26632000060	-	60	54	32	-	-	-	
HFER32-Z3/4"-L1=50	26644000050		50		3/4"				M12
HFER32-Z3/4"-L1=100	26644000100	-	100	52	3/4"	-	-	-	
HFER32-Z1"-L1=50	26646000050		50		1"				M18
HFER32-Z1"-L1=100	26646000100	-	100	40	1"	-	-	-	
HFER32-Z1.1/4"-L1=60	26648000060		60		1.1/4"				M20
HFER40-Z25-L1=50	26725000050	4	50	60	25	63	-	471E•472E	
HFER40-Z1"-L1=50	26746000050		50		1"				M18
HFER40-Z1.1/4"-L1=60	26748000060		60		1.1/4"				M22

Type HFER

Collet Holders with Cylindrical Shank

Picture 1

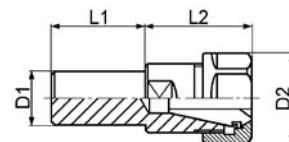

Picture 2

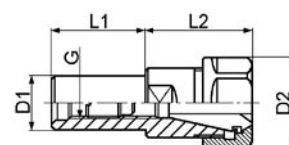

Picture 3

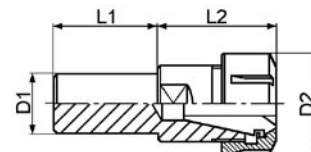

Picture 4

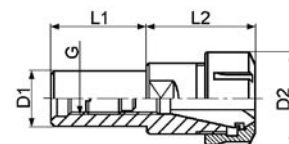

Type HFERM

Collet Holders with Cylindrical Shank

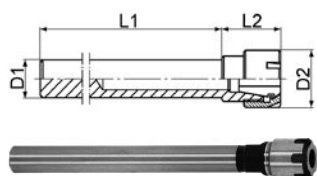

Application – on (long) turning automatic lathes for holding tools with cylindrical shanks in collets DIN6499/ISO15488 (ER/ESX)

Acceptance – cylindrical shank without flat • extremely slim construction

Concentricity and repeatability – shank O.D. to collet closing taper $\leq 5\mu\text{m}$

Remark – collets, wrenches and nuts as spare parts see pages 6 to 16 • other executions on request

Extend of delivery – with mini nut • without collets and wrenches

Description	Order-No.	L1	L2	D1	D2	Collets	
HFER8M-Z6-L1=70	27106000070	70	25	6	12	4004E	
HFER8M-Z8-L1=70	27108000070			8			
HFER8M-Z10-L1=80	27110000090	80	16	10			
HFER8M-Z12-L1=80	27112000080			12			
HFER11M-Z6-L1=56	27206000056	56	29	6	16	4008E	
HFER11M-Z7-L1=56	27207000056			7			
HFER11M-Z8-L1=56	27208000056	60	37	8	22		426E
HFER16M-Z8-L1=60	27308000060			8			
HFER16M-Z10-L1=60	27310000060	80	38	10	28	428E	
HFER16M-Z12-L1=80	27312000080			12			
HFER20M-Z15-L1=100	27415000100	100	38	15	28		428E
HFER20M-Z16-L1=100	27416000100			16			
HFER20M-Z18-L1=70	27418000070			18			

Type HFERM

Collet Holders with Cylindrical Shank

Picture 1

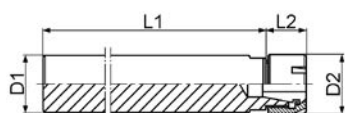

Picture 2

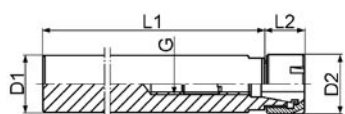

Picture 3

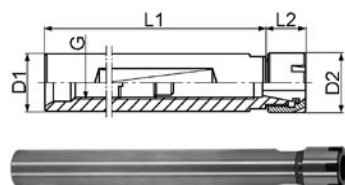

Application – as milling extensions on boring bars for holding tools with cylindrical shanks in collets DIN6499/ISO15488 (ER/ESX)

Acceptance – cylindrical shank without flat • extremely slim construction

Concentricity and repeatability – shank O.D. to collet closing taper $\leq 5\mu\text{m}$

Remark – collets, wrenches and nuts as spare parts see pages 6 to 16 • other executions on request

Extend of delivery – with mini nut and inner stop (only for executions with internal thread) • without collets and wrenches

Description	Order-No.	Pic.	L1	L2	D1	D2	G	Collets
HFER8M-Z8-L1=125	27108000125	1	125	16	8	12	-	4004E
HFER8M-Z12-L1=125	27112000125		125		12			
HFER11M-Z10-L1=80	27210000080	1	80	22	10	16	-	4008E•4012E
HFER11M-Z12-L1=125	27212000125		125		12			
HFER11M-Z16-L1=125	27216000125	3	150	19	16	M7		
HFER11M-Z16-L1=150	27216000150	2			16			
HFER11M-Z5/8"-L1=125	27242000125	3	125	36	5/8"	-	425E•426E	
HFER16M-Z16-L1=150	27316000150	1	150		16			
HFER16M-Z20-L1=140	27320000140	3	140	23	20	22		
HFER16M-Z20-L1=170	27320000170	2	170		20			
HFER16M-Z20-L1=200	27320000200	2	200	22	25	M11	429E•430E	
HFER16M-Z25-L1=150	27325000150		3					150
HFER16M-Z3/4"-L1=125	27344000125	3	125	23	3/4	-		
HFER20M-Z20-L1=150	27420000150		150		20			
HFER20M-Z25-L1=140	27425000140	3	140	24	25	28	M14	
HFER20M-Z25-L1=150	27425000150		150					20
HFER20M-Z25-L1=200	27425000200		200					20
HFER20M-Z1"-L1=140	27446000140		140					1"
HFER25M-Z20-L1=150	27520000150	3	150	45	20	-	M14	
HFER25M-Z25-L1=100	27525000100		100					25
HFER25M-Z25-L1=150	27525000150		150					25
HFER25M-Z30-L1=180	27530000180	3	180	28	30	35	M18	
			180					28

Application – as milling extensions on boring bars for holding tools with cylindrical shanks in collets DIN6499/ISO15488 (ER/ESX)

Acceptance – cylindrical shank with flat • extremely slim construction

Concentricity and repeatability – shank O.D. to collet closing taper $\leq 5\mu\text{m}$

Remark – collets, wrenches and nuts as spare parts see pages 6 to 16

Extend of delivery – with mini nut and inner stop (only for executions with internal thread) • without collets and wrenches

Description	Order-No.	Pic.	L1	L2	D1	D2	G	Collets	
HFER8M-ZW6-L1=70	27156000070	1	70	16	6	10	12	4004E	
HFER8M-ZW8-L1=125	27158000125		125		8				
HFER8M-ZW10-L1=80	27160000080		80						
HFER8M-ZW10-L1=120	27160000120		120						
HFER8M-ZW12-L1=80	27162000080		80		12				
HFER8M-ZW12-L1=125	27162000125		125						
HFER11M-ZW10-L1=80	27260000080	1	80	22	10	16	-	4008E•4012E	
HFER11M-ZW10-L1=120	27260000120		120						
HFER11M-ZW12-L1=125	27262000125	3	125	19	16	M7			
HFER11M-ZW16-L1=125	27266000125		150						
HFER11M-ZW16-L1=150	27266000150	2	150		5/8"				
HFER16M-ZW16-L1=100	27366000100	3	100	36	16	M8	-	425E•426E	
HFER16M-ZW16-L1=150	27366000150	1	150						
HFER16M-ZW20-L1=140	27370000140	3	140	23	20	22	M11		
HFER16M-ZW25-L1=150	27375000150		150						25
HFER16M-ZW3/4"-L1=125	27394000125		125						3/4"
HFER20M-ZW20-L1=150	27470000150	3	150	24	25	28	M14	427E•428E	
HFER20M-ZW25-L1=140	27475000140		140						
HFER20M-ZW25-L1=150	27475000150		150						1"
HFER20M-ZW25-L1=200	27425000200		200						
HFER25M-ZW20-L1=150	27570000150	3	150	36	25	35	M14	429E•430E	
HFER25M-ZW25-L1=100	27575000100		100						
HFER25M-ZW25-L1=150	27575000150		150						
HFER25M-ZW30-L1=180	27580000180		180				28		30

Application – for holding tools with cylindrical shanks in collets DIN6499/ISO15488 (ER/ESX)

Acceptance – cylindrical shank with flat and lateral coolant connection thread • thread in the rear can be used for coolant connection, as closing plug or for an inner stop

Concentricity and repeatability – shank O.D. to collet closing taper $\leq 5\mu\text{m}$

Remark – collets, seals, wrenches and nuts as spare parts see pages 6 to 16 • other executions on request

Extend of delivery – with mini nut for seals HPDI • without collets, seals, wrenches and inner stop

Description	Order-No.	L1	L2	L3	D1	D2	G	Collets
HFER16DM-ZW20-AK1-L1=50	27321000050	50			20			
HFER16DM-ZW22-AK1-L1=70	27323000070	70	13	27	22	25	22	1/8"
HFER16DM-ZW25-AK1-L1=70	27326000070				25			
HFER16DM-ZW3/4"-AK1-L1=50	27345000050	50			3/4"			
HFER16DM-ZW1"-AK1-L1=70	27347000070	70			1"			
HFER20DM-ZW25-AK-L1=150	27426000150	150	-	30	25	28	1/4"	428E
HFER25DM-ZW25-AK-L1=150	27526000150	150	-	32	25	35	1/4"	430E

Type HFERM

Collet Holders with Cylindrical Shank and Flat

Picture 1

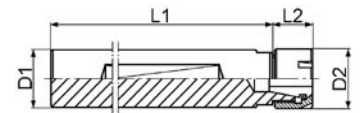

Picture 2

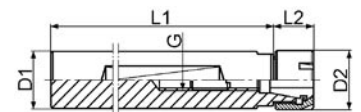

Picture 3

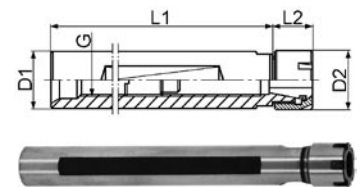

Type HFERDM

Collet Holders with Cylindrical Shank, Flat and Coolant Connection

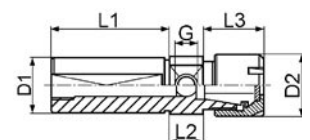

Type HFERM

Collet Holders
with Cylindrical Shank
and Flat

Picture 1

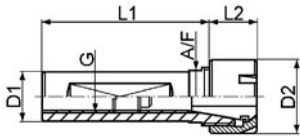

Picture 2

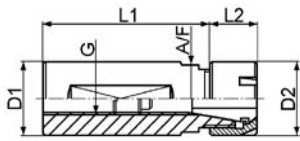

Picture 3

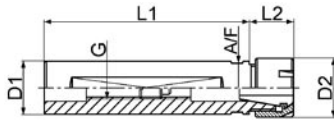

Picture 4

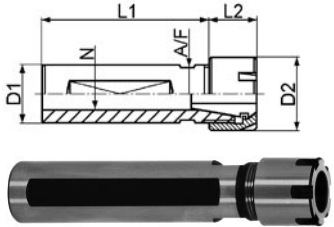

Application – on machines with narrow space proportions (e.g. Star and Traub long turning automatic lathes) for holding tools with cylindrical shanks in collets DIN6499/ISO15488 (ER/ESX)

Acceptance – cylindrical shank with flat • large clamping range with small dimensions • G/N with addition M = inner thread with stop / without addition M = through bore • all holders are available on request with coolant connection thread in the rear

Concentricity and repeatability – shank O.D. to collet closing taper ≤ 5µm

Remark – collets, wrenches and nuts as spare parts see pages 6 to 16 • other executions on request

Extend of delivery – with mini nut and inner stop (only for executions with internal thread) • without collets and wrenches

Description	Order-No.	Pic.	L1	L2	D1	D2	A/F	G/N	Collets
HFER8M-ZW16-L1=45	27116000045	4	45	14	16	12	13	5,5	4004E
HFER8M-ZW5/8"-L1=45	27142000045				5/8"				
HFER11M-ZW12-L1=40	27212000040	2	40	29	12		12	M6	4008E•4012E
HFER11M-ZW14-L1=18	27214000018		18		14		-	7,5	
HFER11M-ZW16-L1=20	27216000020	4	20		16	16	14		
HFER11M-ZW16-L1=80	27216000080		80	19					
HFER11M-ZW20-L1=60	27220000060	2	60		20		17	M7	425E•426E
HFER11M-ZW3/4"-L1=70	27244000070		70		3/4"				
HFER16M-ZW16-L1=20	27316000020	1	20	36	16		17	M8	
HFER16M-ZW16-L1=35	27316000035		35						
HFER16M-ZW16-L1=70	27316000070		70						
HFER16M-ZW16-L1=100	27316000080		100						
HFER16M-ZW20-L1=38	27320000038	2	38	20		22	19	M11	
HFER16M-ZW20-L1=50	27320000050		50						
HFER16M-ZW20-L1=70	27320000070		70						
HFER16M-ZW20-L1=120	27320000120		120						
HFER16M-ZW22-L1=38	27322000038		38						23
HFER16M-ZW22-L1=70	27322000070		70						
HFER16M-ZW22-L1=120	27322000120		120						
HFER16M-ZW25-L1=60	27325000060		60		25		22		
HFER16M-ZW25-L1=100	27325000100		100						
HFER16M-ZW5/8"-L1=35	27342000035	1	35	36	5/8"			M8	427E•428E
HFER16M-ZW3/4"-L1=38	27344000038		38		3/4"	17			
HFER16M-ZW3/4"-L1=50	27344000050		50						
HFER16M-ZW3/4"-L1=70	27344000070		70						
HFER16M-ZW3/4"-L1=120	27344000120	2	120	23				M11	
HFER16M-ZW1"-L1=60	27346000060		60		1"	22			
HFER16M-ZW1"-L1=75	27346000075		75						
HFER16M-ZW1"-L1=100	27346000100		100						
HFER20M-ZW20-L1=50	27420000050	1	50	31	20		-	M12	
HFER20M-ZW22-L1=70	27422000070	4	70		22		19	14	
HFER20M-ZW25-L1=100	27425000100	1	100	27	25	28	22	M14	
HFER20M-ZW3/4"-L1=50	27444000050		50	31	3/4"		-	M12	
HFER20M-ZW1"-L1=38	27446000038		38				22	M14	
HFER20M-ZW1"-L1=100	27446000100		100	27	1"				
HFER25M-ZW20-L1=75	27520000075	3	75	44	20	35	27	M12	
HFER25M-ZW22-L1=75	27522000075				22				M14
HFER25M-ZW25-L1=75	27525000075			38	25			M18	
HFER25M-ZW3/4"-L1=50	27544000050		50	44	3/4"			M12	
HFER25M-ZW3/4"-L1=75	27544000075			75					
HFER25M-ZW1"-L1=75	27546000075			38	1"			M18	

Application – on CNC machines with take up spindle (e.g. Atak, Citizen, Manuhrin, Star etc.) for holding tools with cylindrical shanks in collets DIN6499/ISO15488 (ER/ESX)

Acceptance – cylindrical shank with flat • large clamping range with small dimensions • DHER11/16 and DHER20/25 have different collet closing tapers

Concentricity and repeatability – shank O.D. to collet closing taper $\leq 5\mu\text{m}$

Remark – collets, wrenches and nuts as spare parts see pages 6 to 16 • other executions on request

Extend of delivery – with mini nut • without collets and wrenches

Description	Order-No.	L1	L2/ L3	D1	D2/ D3	A/F	N	Collets
DHER8M-ZW5/8"-L1=18	28142000018	18						
DHER8M-ZW5/8"-L1=29	28142000029	29	14	5/8"	12	13	5,5	4004E
DHER11M-ZW16-L1=32	28216000032	32		16		13		
DHER11M-ZW16-L1=50	28216000050	50						
DHER11M-ZW20-L1=32	28220000032	32						
DHER11M-ZW20-L1=40	28220000040	40		20		17		
DHER11M-ZW20-L1=52	28220000052	52						
DHER11M-ZW20-L1=65	28220000065	65	19		16		7,5	4008E
DHER11M-ZW22-L1=100	28222000100	100		22				
DHER11M-ZW3/4"-L1=32	28244000032	32						
DHER11M-ZW3/4"-L1=40	28244000040	40		3/4"		16		
DHER11M-ZW3/4"-L1=52	28244000052	52						
DHER11M-ZW3/4"-L1=65	28244000065	65						
DHER11/16M-ZW20-L1=32	28221000032	32		20				
DHER11/16M-ZW20-L1=55	28221000055	55	19/ 23		16/ 22	17	7,5	4008E/ 426E
DHER11/16M-ZW3/4"-L1=32	28245000032	32		3/4"				
DHER11/16M-ZW3/4"-L1=55	28245000055	55						
DHER16M-ZW20-L1=32	28320000032	32						
DHER16M-ZW20-L1=55	28320000055	55		20		17		
DHER16M-ZW20-L1=62	28320000062	62						
DHER16M-ZW20-L1=75	28320000075	75						
DHER16M-ZW22-L1=62	28322000062	62						
DHER16M-ZW22-L1=75	28322000075	75						
DHER16M-ZW22-L1=100	28322000100	100	23	22	22	19	11	426E
DHER16M-ZW22-L1=120	28322000120	120						
DHER16M-ZW25-L1=62	28325000062	62		25		22		
DHER16M-ZW3/4"-L1=32	28344000032	32		3/4"		16		
DHER16M-ZW3/4"-L1=55	28344000055	55						
DHER16M-ZW1"-L1=62	28346000062	62		1"		22		
DHER20M-ZW25-L1=100	28425000100	100		25		22		
DHER20M-ZW32-L1=55	28432000055	55				-		
DHER20M-ZW32-L1=85	28432000085	85	25	32	28	27	14	428E
DHER20M-ZW1"-L1=45	28446000045	45		1"		22		
DHER20M-ZW1"-L1=76	28446000076	76						
DHER20/25M-ZW25-L1=62	28426000062	62		25				
DHER20/25M-ZW32-L1=50	28433000050	50	25/ 34	32	28/ 35	27	13	428E/ 430E
DHER20/25M-ZW1"-L1=62	28447000062	62		1"				

Type DHERM

Double Collet Holders
with Cylindrical Shank
and Flat

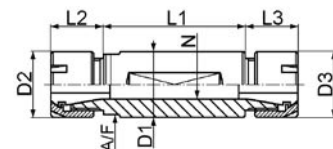

Type HFERM

Collet Holders with B Taper DIN238 and Flat

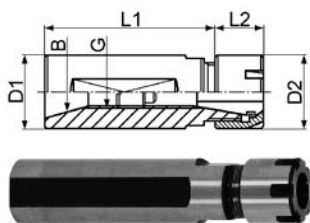

Application – for holding tools with cylindrical shanks in collets DIN6499/ISO15488 (ER/ESX)

Acceptance – with drill chuck taper DIN238 and flat • small dimensions

Concentricity and repeatability – B taper to collet closing taper $\leq 5\mu\text{m}$

Remark – collets, wrenches and nuts as spare parts see pages 6 to 16 • other executions on request

Extend of delivery – with mini nut and inner stop • without collets and wrenches

Description	Order No.	B	L1	L2	D1	D2	G	Collets
HFER11M-B12-L1=40	27202	B12	40	19	16	16	M8	4008E
HFER16M-B12-L1=45	27302	B12	45	23	22	22	M10	426E
HFER20M-B12-L1=50	27402	B12						
HFER20M-B16-L1=50	27403	B16	50	25	25	28	M14	428E
HFER20M-B18-L1=50	27404	B18						

Type HF

Collet Holders with Cylindrical Shank and Flat

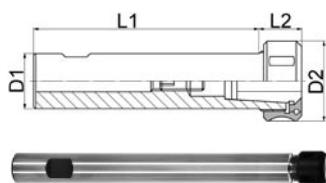

Application – as milling extensions on boring bars for clamping of holding tools with cylindrical shanks in collets DIN6388

Acceptance – cylindrical shank with flat • slim construction

Concentricity and repeatability – shank O.D. to collet closing taper $\leq 10\mu\text{m}$

Remark – collets, wrenches and nuts as spare parts see pages 17 to 20 • further executions on request

Extend of delivery – with clamping nut DIN6388 (one-pieced in case of HF106+HF110 – with ball bearing ring for HF216) and inner stop • without collets and wrenches

Description	Order-No.	L1	L2	D1	D2	Collets
HF106-Z16-L1=140	23412000140	140	19	16	18	400E
HF106-Z20-L1=140	23414000140			20		
HF110-Z20-L1=145	23434000145	145	19	20	30	404E
HF110-Z25-L1=145	23436000145			24		
HF216-Z25-L1=150	23456000150	150	58	25	43	410E•415E•421E

Type BHRFJ

Drill Holders with Cylindrical Shank and Flat

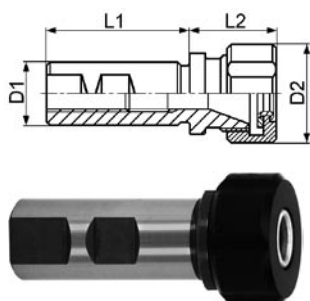

Application – for holding tools with cylindrical shanks in Rubber-Flex[®] collets RFJ with large clamping range

Acceptance – cylindrical shank with flat

Concentricity and repeatability – shank O.D. to collet closing taper $\leq 10\mu\text{m}$

Remark – collets, wrenches and nuts as spare parts see page 24

Extend of delivery – with Rubber-Flex[®] clamping nut • without collets and wrenches

Description	Order-No.	L1	L2 max.	D1	D2	Collets
BHRFJ41-Z16-L1=50	23616	50	23	16	21	710E
BHRFJ41-Z20-L1=52	23620	52	20	20		
BHRFJ42-Z20-L1=52	23720	52	28	20	31	715E
BHRFJ42-Z25-L1=58	23725			25		
BHRFJ44-Z20-L1=52	23820	52	31	20	40	750E
BHRFJ44-Z25-L1=58	23825					

Application – on CNC lathes for holding taps with cylindrical shanks in collets DIN6499/ISO15488 (ER/ESX)

Acceptance – cylindrical shank DIN69880

Special features – 10 mm length compensation on tension (additional length compensation on compression is available on request) • coolant supply max. 15 bar through collet (use either clamping nut HPDI with seals or collets GER-D) or by simple reconstruction through a lateral tube (no pressure limit)

Remark – collets, wrenches and nuts as spare parts see pages 6 to 16 • for tapping high tensile material use tapping collets GER-GB and exchange clamping nut with a nut type B

Extend of delivery – with clamping nut DIN6499/ISO15488 (with hexagon head form D for GBH16 – rest form E with six slots) • without collets and wrench

Description	Order-No.	L1	L2	D1	D2	D3	H	Collets
GBH16D-D16	59802	32	44	16	40	28	20	425E•426E•4031E (M1-M10)
GBH16D-D20	59804	40	62	20	50		25	
GBH25D-D16	59822	32	73	16	40	42	20	429E•430E•4282E (M3-M20)
GBH25D-D20	59824	40		20	50		25	
GBH25D-D30	59826	55	68	30	68		28	
GBH25D-D40	59828	63	70	40	83		32,5	
GBH25D-D50	59830	78	70	50	98	35		
GBH32D-D30	59846	55	71	30	68	50	28	471E•470E•4537E (M6-M28)
GBH32D-D40	59848	63	76	40	83		32,5	
GBH32D-D50	59850	78		50	98		35	

Application – on CNC lathes for holding reamers with cylindrical shanks in collets DIN6499/ISO15488 (ER/ESX)

Acceptance – cylindrical shank DIN69880

Special features – floating all-round approx. 1 mm (parallel floating) adjustable by means of a adjusting nut • coolant supply max. 15 bar through collet (use either clamping nut HPDI with seals or collets GER-D)

Remark – collets, wrenches and nuts as spare parts see pages 6 to 16

Extend of delivery – with clamping nut DIN6499/ISO15488 (form E with six slots) • without collets and wrenches

Description	Order-No.	L1	L2	D1	D2	D3	H	Collets
PHER25D-D20	76521	40	73	20	50	42	25	429E•430E
PHER25D-D30	76531	55	68	30	68		28	
PHER25D-D40	76541	63	70	40	83		32,5	
PHER25D-D50	76551	78	70	50	98		35	

Type GBH

VDI Tapping Holders with Shank DIN69880

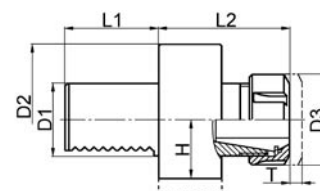

Type PHER

VDI Floating Reamer Holders with Shank DIN69880

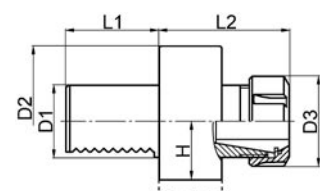

Type GBH

Tapping Holders with Cylindrical Shank

Picture 1

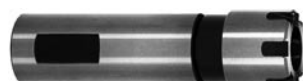
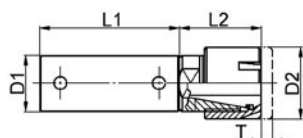

Picture

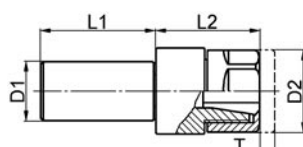

Picture 3

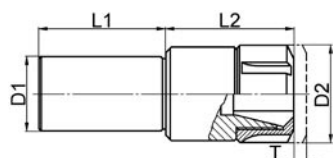

Application – for holding taps with cylindrical shanks in collets (ER/ESX)

Acceptance – cylindrical shank without flat

Special features – length compensation on tension (T) see chart (all holders with the exception of GBH11M and 16M are available as special executions with additional length compensation on compression) • extremely slim construction (especially holders with mini nut) • ball guided • inner coolant supply at GBH32D max. 20 bar (use either clamping nut HPDI with seals or collets GER-D) • small differences to drawing are possible

Remark – collets, wrenches and nuts as spare parts see pages 6 to 16 • other executions on request • for tapping high tensile material use tapping collets GER-GB and exchange clamping nut with a nut type B

Extend of delivery – with clamping nut DIN6499/ISO15488 (mini nut for GBH11M and 16M – with hexagon head form D for GBH20 – rest form E with six slots) • without collets and wrench

Description	Order-No.	Pic.	L1	L2	D1	D2	T	Collets
GBH11M-Z20-L1=50	59270000050	1	50	15	20	16	7	4008E•4016E (M1-M6)
GBH11M-Z22-L1=70	59272000070		70		22			
GBH11M-Z25-L1=70	59275000070		70		25			
GBH11M-Z3/4"-L1=50	59294000050		50		3/4"			
GBH11M-Z1"-L1=70	59296000070		70		1"			
GBH16M-Z20-L1=50	59370000050	1	50	29	20	22	7	426E•4031E (M1-M8)
GBH16M-Z22-L1=70	59372000070		70		22			
GBH16M-Z25-L1=70	59375000070		50		25			
GBH16M-Z3/4"-L1=50	59394000050		50		3/4"			
GBH16M-Z1"-L1=70	59396000070		70		1"			
GBH20-Z16-L1=32	59416000032	2	32	55	16	34	10	428E•4276E (M2-M16)
GBH20-Z20-L1=50	59420000050		50		20			
GBH20-Z25-L1=100	59425000100		100		25			
GBH20-Z32-L1=55	59432000055		55		32			
GBH20-Z3/4"-L1=50	59444000050		50		3/4"			
GBH20-Z1"-L1=100	59446000100	100	1"					
GBH25-Z20-L1=50	59520000050	3	50	55	20	42	12	430E•4282E (M3-M16)
GBH25-Z25-L1=45	59525000045		45		25			
GBH25-Z25-L1=100	59525000100		100		25			
GBH25-Z32-L1=55	59532000055		55		32			
GBH25-Z3/4"-L1=50	59544000050		50		3/4"			
GBH25-Z1"-L1=100	59546000100	100	1"					
GBH32D-Z20-L1=50	59620000050	3	50	63	20	50	10	469E•470E•4537E (M6-M28)
GBH32D-Z25-L1=50	59625000050		50		25			
GBH32D-Z32-L1=60	59632000060		60		32			
GBH32D-Z40-L1=70	59640000070		70		40			
GBH32D-Z3/4"-L1=50	59644000050		50		3/4"			
GBH32D-Z1"-L1=50	59646000050	50	1"					

Application – on CNC machines with take up spindle (e.g. Atak, Citizen, Manuhrin, Star etc.) for holding taps with cylindrical shanks in collets DIN6499/ISO15488 (ER/ESX)

Acceptance – cylindrical shank with flat

Special features – 8 mm length compensation on tension (T) • small dimensions (especially holders with mini nut)

Remark – collets, wrenches and nuts as spare parts see pages 6 to 16 • other executions on request

Extend of delivery – with clamping nut DIN6499/ISO15488 (with hexagon head form D for DGBH11 – mini nut with DGBH16M) • without collets and wrench

Description	Order-No.	L1	L2/L3	D1	D2/D3	A/F	Collets
DGBH11-ZW20-L1=48	5822000048			20			
DGBH11-ZW22-L1=48	5822200048	48	15	22	19	-	4008E•4016E (M1-M6)
DGBH11-ZW3/4"-L1=48	5824400048			3/4"			
DGBH16M-ZW20-L1=57	5837000057			20			
DGBH16M-ZW22-L1=57	5837200057	57	35/28	22	22	17	426E•4031E (M1-M8)
DGBH16M-ZW3/4"-L1=57	5839400057			3/4"			
DGBH16M-ZW1"-L1=69	5839600069	69	35	1"			

Application – on CNC machines with take up spindle (e.g. Atak, Citizen, Manuhrin, Star etc.) for holding tools/taps with cylindrical shanks in collets DIN6499/ISO15488 (ER/ESX)

Acceptance – cylindrical shank with flat

Special features – on one side is a stiff collet closing taper and on the other side a length compensation of 8 mm on tension (T)

Remark – collets, wrenches and nuts as spare parts see pages 6 to 16 • other executions on request

Extend of delivery – with mini nuts • without collets and wrench

Description	Order-No.	L1	L2/L3	D1	D2/D3	Collets
HFER/GBH11M-ZW20-L1=32	5727000032	32				
HFER/GBH11M-ZW20-L1=52	5727000052	52	15	20	16	4008E•4016E (M1-M6)
HFER/GBH16M-ZW20-L1=70	5737000070			20		
HFER/GBH16M-ZW22-L1=70	5737200070	70	23	22	22	426E•4031E (M1-M8)
HFER/GBH16M-ZW3/4"-L1=70	5739400070			3/4"		

Type DGBH

Double Tapping Holders with Cylindrical Shank and Flat

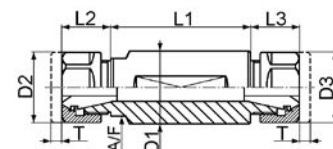

Type HFER/GBH

Drill-Tapping Holders with Cylindrical Shank and Flat

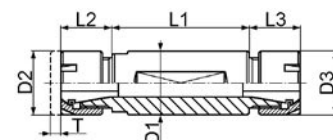

Type PHER

**Floating Reamer Holders
with Cylindrical Shank**

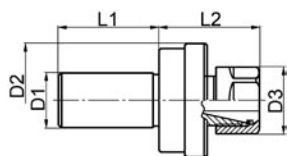

Application – for holding reamers with cylindrical shanks in collets DIN6499/ISO15488 (ER/ESX)

Acceptance – cylindrical shank without flat

Special features – floating all-round approx. 1 mm (free floating and parallel floating) adjustable by means of an adjusting nut • spring power adjustable • holders with coolant supply on request

Remark – collets, wrenches and nuts as spare parts see pages 6 to 16

Extend of delivery – with clamping nut DIN6499/ISO15488 (clamping nuts with external thread for PHER11A – with hexagon head form D for PHER16 and 20 – rest form E with six slots) • without collets and wrenches

Description	Order-No.	L1	L2	D1	D2	D3	Collets
PHER11A-Z16	76216	35	31	16	39	22	4008E
PHER11A-Z20	76220			20			
PHER11A-Z5/8"	76242			5/8"			
PHER11A-Z3/4"	76244			3/4"			
PHER16-Z16	76316	46	38	16	42	28	426E
PHER16-Z20	76320			20			
PHER16-Z22	76322			22			
PHER16-Z25	76325			25			
PHER11-Z5/8"	76342			5/8"			
PHER16-Z3/4"	76344			3/4"			
PHER16-Z1"	76346	1"					
PHER20-Z16	76416	46	45	16	48	34	428E
PHER20-Z20	76420			20			
PHER20-Z25	76425		25				
PHER20-Z3/4"	76444		3/4"				
PHER20-Z1"	76446	45	1"				
PHER25-Z16	76516	46	47	16	57	42	430E
PHER25-Z20	76520			20			
PHER25-Z22	76522			22			
PHER25-Z25	76525			25			
PHER25-Z3/4"	76544		3/4"				
PHER25-Z1"	76546		1"				
PHER32-Z25	76625	50	57	25	68	50	470E
PHER32-Z30	76630			30			
PHER32-Z32	76632			32			
PHER32-Z1"	76646			1"			
PHER32-Z1.1/4"	76648			1.1/4"			

Application – for holding reamers with cylindrical shanks in collets DIN6499/ISO15488 (ER/ESX)

Acceptance – cylindrical shank without flat • extremely slim construction

Special features – floating exactly parallel 1mm in all directions • self-centering • no tilting possible

Remark – collets, wrenches and nuts as spare parts see pages 6 to 16 • other executions on request

Extend of delivery – with clamping nut DIN6499/ISO15488 (with hexagon head form D for PHER11 – mini nut for PHER16M) • without collets and wrenches

Description	Order-No.	L1	L2	L3	D1	D2	D3	H	Collets
PHER11-Z16-L1=50	77216000050	50			16				4008E
PHER11-Z20-L1=50	77220000050				20				
PHER11-Z22-L1=70	77222000070	70	15	20	22	45	19	24	4008E
PHER11-Z25-L1=70	77225000070				25				
PHER11-Z3/4"-L1=50	77244000050	50			3/4"				
PHER11-Z1"-L1=70	77246000070	70			1"				
PHER16M-Z16-L1=50	77366000050	50			16				426E
PHER16M-Z20-L1=50	77370000050				20				
PHER16M-Z22-L1=70	77372000070	70	15	30	22	45	22	24	426E
PHER16M-Z25-L1=70	77375000070				25				
PHER16M-Z3/4"-L1=50	77394000050	50			3/4"				
PHER16M-Z1"-L1=70	77396000070	70			1"				

Application – for holding reamers with cylindrical shanks in collets DIN6499/ISO15488 (ER/ESX)

Acceptance – cylindrical shank without flat with coolant connection thread in the rear • extremely slim construction

Special features – floating exactly parallel 1mm in all directions • self-centering • no tilting possible • coolant supply max. 20 bar through collet

Remark – collets, seals, wrenches and nuts as spare parts see pages 6 to 16 • other executions and size PHER11D on request

Extend of delivery – with mini nut for seals HPDI • without collets, seals and wrenches

Description	Order-No.	L1	L2	L3	D1	D2	D3	G	H	Collets
PHER16DM-Z16-L1=50	77367000050	50			16			1/8"		426E
PHER16DM-Z20-L1=50	77371000050				20					
PHER16DM-Z22-L1=70	77373000070	70	15	34	22	45	22	1/4"	24	426E
PHER16DM-Z25-L1=70	77376000070				25					
PHER16DM-Z3/4"-L1=50	77395000050	50			3/4"			1/8"		
PHER16DM-Z1"-L1=70	77397000070	70			1"			1/4"		

Type PHER/PHERM

Floating Reamer Holders with Cylindrical Shank

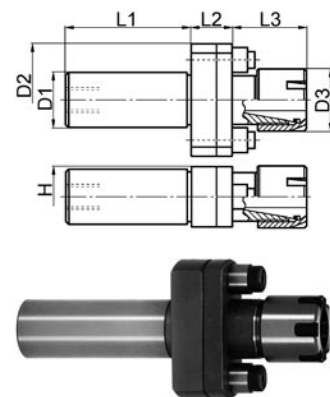

Type PHERDM

Floating Reamer Holders with Cylindrical Shank and Coolant Connection

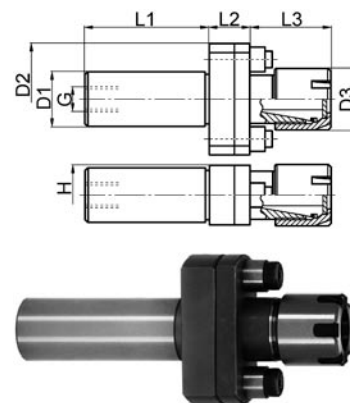

Concentricity Charts

Concentricity
DIN6499/ISO15488
(ER/ESX) resp.
FAHRION Quality

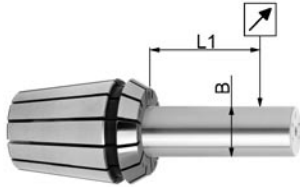

Concentricity for collets DIN6499/ISO15488 (ER/ESX) on pages 6 to 12.

The tolerances are classified to DIN into two classes:

- Class 2 is our standard for forms K2 and ET (on pages 9 and 12)
- Class 1 (higher TIR) is our standard for form GB (on page 11)
- FAHRION quality is our standard (average concentricity with a repeatability of 3 resp. 6µm) for forms B, HP, HP+, D and DD – details and exceptions see ☒ at the respective description (on pages 6 to 8 and 10)

Test method (except for HP and HP+) see below

B mm	L1 mm	DIN		FAHRION Quality	
		Class 2	Class 1	B, D + DD	HP + HP+ *
over 1,0 bis 1,6	2-3	0,015	0,010	0,006	0,003
1,6 bis 3,0	10				
3,0 bis 7,0	16				
7,0 bis 10,0	25				
10,0 bis 18,0	40	0,020	0,015		
18,0 bis 26,0	50				
26,0 bis 34,0	60				
		0,025	0,020	0,015	-

* checked with HPplus chuck in four equi-spaced positions (moved clockwise by 90°) at a distance of 3xD (max. 50 mm)

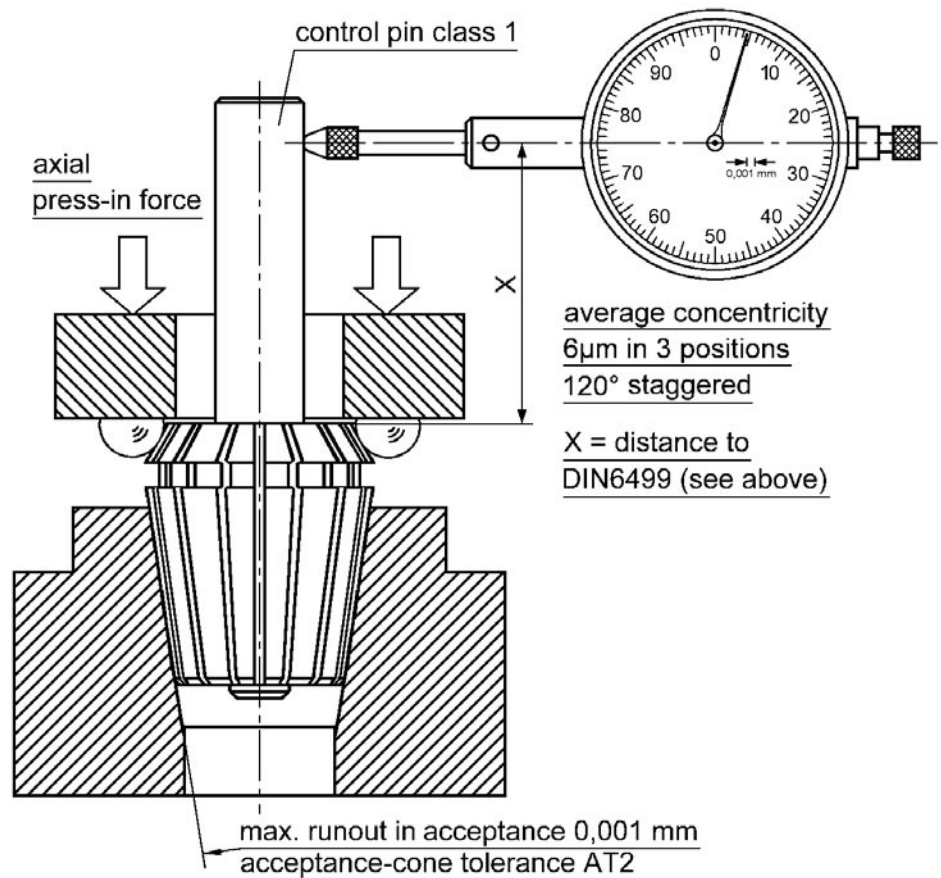

For applications which require highest concentricity, it is absolutely necessary to pay attention to the complete system (machine spindle, collet acceptance, clamping nut, collet and cutting tool).

Concentricity for collets DIN6388/ISO10897 (OZ) on pages 17 to 20.

The tolerances are classified to DIN into two classes:

- Class 2 is our standard for forms A6, RT, K2 and C (on pages 18 to 20)
- FAHRION quality is our standard (average concentricity with a repeatability of 6µm) for forms A8 and B – details and exceptions see  at the respective description (on pages 17 and 19)

Test method see DIN6499/ISO15488 (ER/ESX)

B mm	L1 mm	DIN Class 2	Class 1	FAHRION Quality
over 1,0 to 1,6	2-3	0,015	0,010	-
1,6 to 3,0	10			
3,0 to 7,0	16			
7,0 to 10,0	25			
10,0 to 18,0	40	0,020	0,015	0,006
18,0 to 25,0	50			
25,0 to 30,0	60			
30,0 to 40,0	60			
		0,030	0,020	0,015

For applications which require highest concentricity, it is absolutely necessary to pay attention to the complete system (machine spindle, collet acceptance, clamping nut, collet and cutting tool).

Remark – the exact tolerances for the manufacture of your spindle are available upon request

Description	Pic.	L1	L2	D1	D2	G	α	Collets	range		
STM11D	1	17	10	11	7,5	M14x0,75	8°	4008E	0,5-7,0		
STM16D+E		22	13	16	10,5	M22x1,5		426E	0,5-10,0		
STM20D+E		26,5	13,5	20	13,5	M25x1,5		428E	0,5-3,0		
STM25E		30	14	25	17,5	M32x1,5		430E	0,5-16,0		
STM32E		35	16	32	23,5	M40x1,5		470E	1,0-20,0		
STM40E		40	17	40	30,5	M50x1,5		472E	2,0-26,0		
STM50E		48	24	50	38	M64x2		477E	4,0-34,0		
STM8M		1	13	7,5	8	5,2		M10x0,75	8°	4004E	0,5-5,0
STM11M	17		10	11	7,5	M13x0,75	4008E	0,5-7,0			
STM16M	22		13	16	10,5	M19x1	426E	0,5-10,0			
STM20M	26,5		13,5	20	13,5	M24x1	428E	0,5-13,0			
STM25M	30		14	25	17,5	M30x1	430E	0,5-16,0			
STM11A	2		23	7	11	7,5	M18x1	8°		4008E	0,5-7,0
STM16A			32	10	16	10,5	M24x1			426E	0,5-10,0
STM20A			37,5	11	20	13,5	M28x1,5			428E	0,5-13,0
STM25A		41	12	25	18	M32x1,5	430E		0,5-16,0		
STM32A		48	14	32	23,5	M40x1,5	470E		1,0-20,0		

Concentricity Charts

Concentricity DIN6388/ISO10897 (OZ) resp. FAHRION-Quality

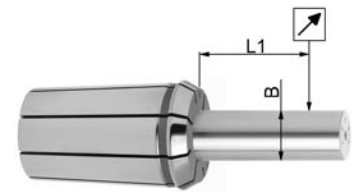

Build-in Dimensions

Collets and Clamping Nuts DIN6499/ISO15488 (ER/ESX)

Picture 1

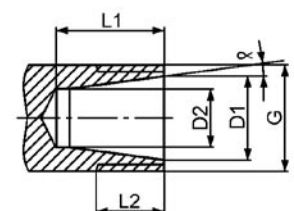

Picture 2

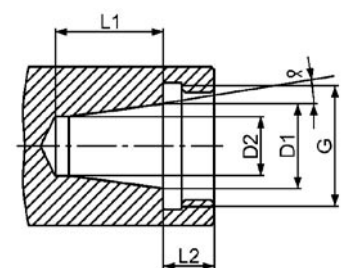

**Tightening Torque for
Clamping Nuts DIN6499/
ISO15488 (ER/ESX)**

Picture 1

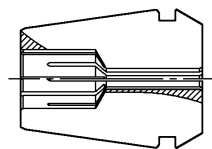

Picture 2

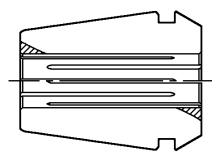

Remark – the tables below show the maximum tightening torque values in relation to the clamping-Ø of the collet with short bore or through bore (see pictures 1 and 2) • the smaller the clamping-Ø the lower the necessary torque value • high torque leads to damage of clamping nut resp. collet closing tape

Collet type	Clamping Nuts	with short bore (Picture 1)		with through bore (Picture 2)			
		Clamping-Ø	max. torque	Clamping-Ø	max. torque		
GER8	STM8M	1,0-2,5	5 Nm	3,0-5,0	8 Nm		
GER11	STM11D + B	1,0-2,5	13 Nm	3,0-7,0	25 Nm		
	GMER11-HG		11 Nm		18 Nm		
	STM11M		13 Nm		24 Nm		
	STM11A						
GER12	STM12D + B	1,0-2,5	13 Nm	3,0-7,0	25 Nm		
GER16	STM16D + B	1,0-4,5	30 Nm	5,0-10,0	50 Nm		
	STM16E-G + B						
	GMER16-HG						
	STM16E-HPDI + B						
	STM16M					18 Nm	28 Nm
	STM16M-HPDI					22 Nm	35 Nm
	STM16A						
GER20	STM20D + B	1,0-6,5	45 Nm	7,0-13,0	75 Nm		
	STM20E-G + B						
	GMER20-HG						
	STM20E-HPDI + B						
	STM20M					22 Nm	35 Nm
	STM20M-HPDI	24 Nm	40 Nm				
	STM20A						
GER25	STM25E-G + B	1,0-6,5	55 Nm	7,0-16,0	85 Nm		
	GMER25-HG						
	STM25E-HPDI + B						
	STM25M					24 Nm	40 Nm
	STM25M-HPDI					28 Nm	46 Nm
	STM25A						
GER32	STM32E-G + B	2,0-6,5	70 Nm	7,0-20,0	105 Nm		
	GMER32-HG						
	STM32E-HPDI + B						
	STM32A					36 Nm	60 Nm
GER40	STM40E-G + B	3,0-7,5	100 Nm	8,0-26,0	150 Nm		
	STM40E-HPDI + B						
GER50	STM50E-G + B	6,0-10,0	120 Nm	12,0-34,0	200 Nm		

Mounting – feed the collet into the nut and turn until the eccentric ring of the nut engages in the groove of the collet. Mount the collet only into the collet chuck or the machine spindle when the nut and the collet are engaged

Remark – do not clamp shanks larger than the nominal size indicated

Mounting – lay the collet in the groove and press axially until it is fixed (picture 1). Please take care that the collet is only clamped with the inserted cutting tool

Changing – remove the nut and again through a lateral pressure the collet springs out of the groove of the nut (picture 2)

Remark – do not clamp shanks larger than the nominal size indicated

Mounting

Mounting Instruction for Collets DIN6499/ISO15488 (ER/ESX)

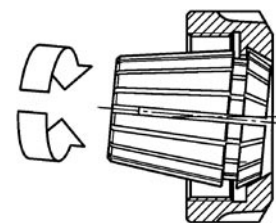

Mounting

Mounting Instruction for Collets DIN6388/ ISO10897 (OZ)

Picture 1

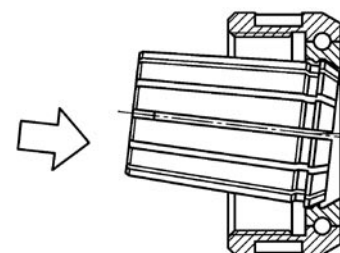

Picture 2

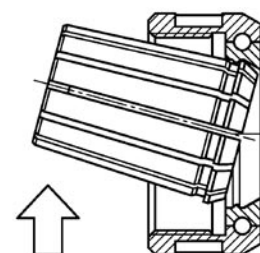

DIN
Tap Shank Dimensions

 Ø x □	DIN352	DIN5156 DIN5157	DIN371	DIN374	DIN376	BSW DIN2183	BSW reinforce DIN2182	UNC DIN376	UNC reinforce DIN371	UNF DIN374	UNF reinforce DIN371
2,5x2,1	M1		M1		M3,5		1/16"				
	M1,1		M1,1	M3,5							
	M1,2		M1,2								
	M1,4		M1,4								
	M1,6		M1,6								Nr.2-64
	M1,8		M1,8						Nr.6-32		Nr.6-40
2,8x2,1	M2		M2	M4	M4	5/32"	3/32"				
	M2,2		M2,2						Nr.2-56		
	M2,5		M2,5						Nr.3-48	Nr.8-36	
3,5x2,7	M3		M3	M5	M5		1/8"		Nr.5-40	Nr.5-44	
4x3	M3,5		M3,5				7/32"	Nr.12-24	Nr.6-32	Nr.12-28	Nr.6-40
4,5x3,4	M4		M4	M6	M6	1/4"	5/32"	1/4"-20	Nr.8-32	1/4"-28	Nr.8-36
5,5x4,5				M7	M7						
6x4,9	M5	G1/16"	M4,5						5/16"-18		Nr.10-32
	M6		M5						Nr.10-24		Nr.12-28
	M8		M6	M8	M8				Nr.12-24		
7x5,5	M10	G1/8"	M7	M9+M10	M9+M10	3/8"	1/4"	3/8"-16	1/4"-20	3/8"-24	1/4"-28
8x6,2			M8			7/16"	5/16"		5/16"-18		5/16"-24
9x7	M12		M9	M12	M12	1/2"	3/8"	1/2"-13	3/8"-16	1/2"-20	3/8"-24
10x8			M10								
11x9	M14	G1/4"		M14	M14	9/16"					
12x9	M16	G3/8"		M16	M16	5/8"		5/8"-11		5/8"-18	
14x11	M18			M18	M18	11/16"		3/4"-10		3/4"-16	
16x12	M20	G1/2"		M20	M20	13/16"					
18x14,5	M22	M5/8"		M22	M22	7/8"					
	M24			M24	M24	15/16"					
20x16	M27	G3/4"		M27	M27	1"					
22x18	M30	G7/8"		M30	M30	1.1/8"					
25x20	M33	G1"		M33	M33	1.1/4"					
28x22	M36	G1.1/8"		M36	M36	1.3/8"					
32x24	M39	G1.1/4"		M39	M39	1.1/2"					
	M42			M42	M42	1.5/8"					
36x29	M45	G1.3/8"		M45	M45	1.3/4"					
	M48	G1.1/2"		M48	M48	1.7/8"					
		G1.3/4"									
40x32	M52	G2.1/4"		M52	M52	2"					
45x35	M56	G2.1/2"			M56	2.1/4"					
	M60				M60						
50x39	M64	G2.3/4"			M64	2.1/2"					
		G3"									
56x44	M68	G3.1/4"			M68	2.3/4"					
						3"					

**ISO
Tap Shank Dimensions**

Ø x □	ISO 529-1975										
	Metric reinforce		UNC reinforce		UNF reinforce		BSW reinforce		BSF reinforce		BA reinforce
2,24x1,8	M3		Nr.5-40		Nr.5-44		1/8"-40				Nr.5
2,5x2,0	M3,5	M2	Nr.6-32	Nr.1-64	Nr.6-40	Nr.0-80					Nr.11
						Nr.1-72					Nr.10
											Nr.9
2,8x2,24		M2,2		Nr.2-56		Nr.2-64					Nr.8
		M2,5		Nr.3-48		Nr.3-56					Nr.7
3,15x2,5											Nr.6
	M4	M3		Nr.4-40		Nr.4-48					Nr.5
3,55x2,8			Nr.8-32	Nr.5-40	Nr.8-36	Nr.5-44					Nr.3
4x3,15	M4,5	M3,5	Nr.10-24	Nr.6-32	Nr.10-32	Nr.6-40	3/16"-24		3/16"-32		Nr.2
4,5x3,55	M5	M4	Nr.12-24		Nr.12-28				7/32"-28		Nr.1
5x4	M6		1/4"-20	Nr.8-32	1/4"-28	Nr.3-36	1/4"-20		1/4"-26		Nr.0
5,6x4,5		M5		Nr.10-24		Nr.10-32		3/16"-24		3/16"-32	Nr.2
6,3x5				Nr.12-24		Nr.12-28			9/32"-26	7/32"-28	Nr.1
7,1x5,6	M8	M6	5/16"-18	1/4"-20	5/16"-24	1/4"-28	5/16"-18	1/4"-20	5/16"-22	1/4"-26	Nr.0
8x6,3			3/8"-16		3/8"-24		3/8"-24		3/8"-20	9/32"-26	
9x7,1	M10	M8	7/16"-14	5/16"-18	7/16"-20		7/16"-14	5/16"-18	7/16"-18	5/16"-22	
10x8		M10									
11,2x9			3/8"-16		3/8"-24		3/8"-16		3/8"-20		
12,5x10	M14		9/16"-12		9/16"-18		9/16"-12		9/16"-16		
14x11,2	M16		5/8"-11		5/8"-18		5/8"-11		3/8"-14		
16x12,5	M18		3/4"-10		3/4"-16		11/16"-11		11/16"-14		
	M20						3/4"-10		3/4"-12		
18x14	M22		7/8"-9		7/8"-14		7/8"-9		7/8"-11		
20x16	M24		1"-8		1"-12		1"-8		1"-10		
	M27		1.1/8"-7		1.1/8"-12		1.1/8"-7		1.1/8"-9		
22,4x18	M30										
25x20	M33		1.1/4"-7		1.1/4"-12		1.1/4"-7		1.1/4"-9		
28x22,4	M36		1.3/8"-6		1.3/8"-12				1.3/8"-8		
	M39		1.1/2"-6		1.1/2"-12		1.1/2"-6		1.1/2"-8		
31,5x25	M42								1.5/8"-8		
	M45		1.3/4"-5				1.3/4"-5		1.3/4"-7		
35,5x28	M48										
	M52		2"-4.1/2				2"-4.1/2		2"-7		
40x31,5	M56										
	M60		2.1/4"-4.1/2				2.1/4"-4		2.1/4"-6		
45x35,5	M64		2.1/2"-4				2.1/2"-4		2.1/2"-6		
	M68		2.3/4"-4				2.3/4"-3.1/2		2.3/4"-6		
50x40			3"-4				3"-3.1/2		3"-5		
			3.1/4"-4				3.1/4"-3.1/4		3.1/4"-5		
			3.1/2"-4				3.1/2"-3.1/4		3.1/2"-4.1/2		
56x45			3.3/4"-4				3.3/4"-3		3.3/4"-4.1/2		
			4"-4				4"-3		4"-4.1/2		

■ Tool Clamping

www.fahrion.de

Request our detailed catalogues for other Fahrion products.



■ Precision Collet Chucks
HP plus



■ Collet Chucks
Centro P

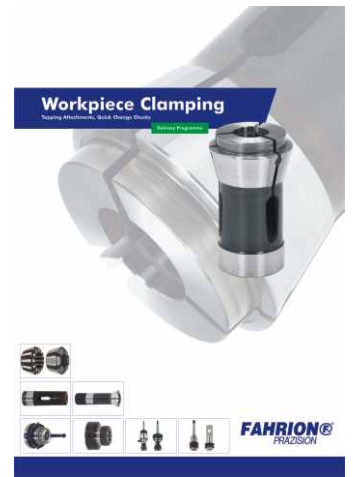

■ Workpiece Clamping,
Tapping Attachments,
Quick Change Chucks

FAHRION Vertriebs-GmbH

Forststrasse 54
DE-73667 Kaisersbach

Phone +49 (0) 71 84 92 82-0

Fax +49 (0) 71 84 92 82-92

Internet: www.fahrion.de

E.Mail: info@fahrion.de

